







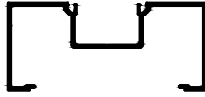

# CASCADE ALUMINUM, INC.

ENTRANCES, EXTRUSIONS & ANODIZING

## SERIES # 450-CS 2" x 4 1/2" CENTER GLAZE

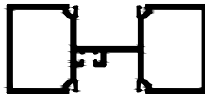
1" INSULATED GLASS SYSTEM FOR INTERIOR AND EXTERIOR GLAZING

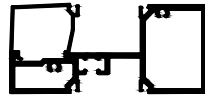
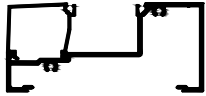
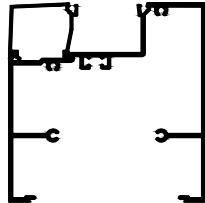
### QUARTER SIZE DETAILS

 <p>(DETAIL # 1) VERTICAL OR HEAD</p> <p><b>PART# V452</b></p> <p>CLEAR 24' 1" _____.00 BRONZE 24' 1" _____.00</p>	 <p>(DETAIL # 2) VERTICAL NO SPLINE</p> <p><b>PART# V452R</b></p> <p>CLEAR 24' 1" _____.00 BRONZE 24' 1" _____.00</p>	 <p>(DETAIL # 3) VERTICAL NO SPLINE</p> <p><b>PART# V452R</b></p> <p>CLEAR 20' 1" _____.00 BRONZE 20' 1" _____.00</p>	 <p>(DETAIL # 4) INTERMEDIATE VERTICAL</p> <p><b>PART# IV452</b></p> <p>CLEAR 24' 1" _____.00 BRONZE 24' 1" _____.00</p>
 <p>(DETAIL # 5) HEAVY WALL VERTICAL</p> <p><b>PART# H452</b></p> <p>CLEAR 15' 6" _____.00 BRONZE 15' 6" _____.00</p>	 <p>(DETAIL # 6) ONE PIECE VERTICAL</p> <p><b>PART# V215</b></p> <p>CLEAR 24' 1" _____.00 BRONZE 24' 1" _____.00</p>	 <p>(DETAIL # 7) POCKET FILLER</p> <p><b>PART# IF200</b></p> <p>CLEAR 24' 1" _____.00 BRONZE 24' 1" _____.00</p>	 <p>(DETAIL # 8) INTERMEDIATE HORIZONTAL</p> <p><b>PART# H450/ST</b></p> <p>CLEAR 24' 1" _____.00 BRONZE 24' 1" _____.00</p>
 <p>(DETAIL # 9) SILL OR INTERMEDIATE HORIZONTAL W/ IF200</p> <p><b>PART# H200/ST</b></p> <p>CLEAR 24' 1" _____.00 BRONZE 24' 1" _____.00</p>	 <p>(DETAIL # 10) 4 1/2" X 4 1/2" SILL OR INTERMEDIATE HORIZONTAL W/ IF200</p> <p><b>PART# IB200/ST</b></p> <p>CLEAR 24' 1" _____.00 BRONZE 24' 1" _____.00</p>	 <p>(DETAIL # 11) GLASS STOP FOR H200, H450, IB200 AND SI450</p> <p><b>PART# HS450</b></p> <p>CLEAR 24' 1" _____.00 BRONZE 24' 1" _____.00</p>	 <p>(DETAIL # 12) TWO PIECE COMPENSATION CHANNEL INCLUDES GASKET</p> <p><b>PART# CC 450/ST</b></p> <p>CLEAR 24' 1" _____.00 BRONZE 24' 1" _____.00</p>

CASCADE ALUMINUM, INC. HAS NO CONTROL OVER THE USE OF IT'S PRODUCTS.

THE OWNER, THE ARCHITECT AND THE INSTALLER ARE RESPONSIBLE FOR THE SELECTION OF THE PROPER SYSTEMS AND SIZES TO COMPLY WITH ALL APPLICABLE BUILDING AND SAFETY LAWS.







# CASCADE ALUMINUM, INC.

ENTRANCES, EXTRUSIONS & ANODIZING

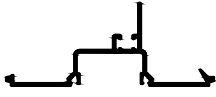
## SERIES # 450-CS 2" x 4 1/2" CENTER GLAZE

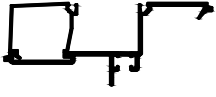
1" INSULATED GLASS SYSTEM FOR INTERIOR AND EXTERIOR GLAZING

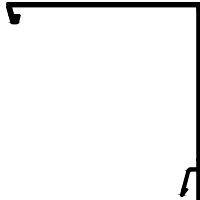
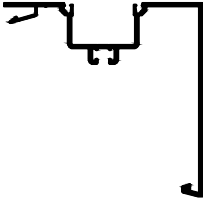
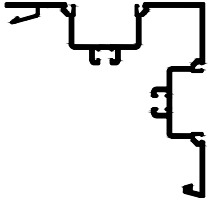
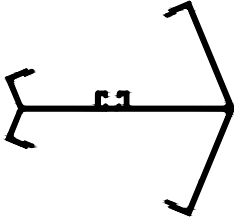
### QUARTER SIZE DETAILS

 <p>(DETAIL # 13)</p> <p>HEAD CAN OR COMPENSATION CHANNEL</p> <p><b>PART# IHC450</b></p>	 <p>(DETAIL # 14)</p> <p>HEAD CAN INSERT</p> <p><b>PART# IHI450</b></p>	 <p>(DETAIL # 15)</p> <p>SILL CAN</p> <p><b>PART# SC450</b></p>	 <p>(DETAIL # 16)</p> <p>SILL CAN INSERT WITH STOP</p> <p><b>PART# SI450/ST</b></p>
<p>CLEAR 24' 1" _____.00</p> <p>BRONZE 24' 1" _____.00</p>	<p>CLEAR 24' 1" _____.00</p> <p>BRONZE 24' 1" _____.00</p>	<p>CLEAR 24' 1" _____.00</p> <p>BRONZE 24' 1" _____.00</p>	<p>CLEAR 24' 1" _____.00</p> <p>BRONZE 24' 1" _____.00</p>
 <p>(DETAIL # 17)</p> <p>ENCAPSULATED SILL FLASHING</p> <p><b>PART# SF200</b></p>	 <p>(DETAIL # 18)</p> <p>SILL FLASHING</p> <p><b>PART# SF100</b></p>	 <p>(DETAIL # 19)</p> <p>CORNER POST BEAUTY CAP</p> <p><b>PART# CP450</b></p>	 <p>(DETAIL # 20)</p> <p>SINGLE POCKET CORNER POST</p> <p><b>PART# CP451</b></p>
<p>CLEAR 24' 1" _____.00</p> <p>BRONZE 24' 1" _____.00</p>	<p>CLEAR 24' 1" _____.00</p> <p>BRONZE 24' 1" _____.00</p>	<p>CLEAR 24' 1" _____.00</p> <p>BRONZE 24' 1" _____.00</p>	<p>CLEAR 24' 1" _____.00</p> <p>BRONZE 24' 1" _____.00</p>
 <p>(DETAIL # 21)</p> <p>DOUBLE POCKET CORNER POST</p> <p><b>PART# CP452</b></p>	 <p>(DETAIL # 22)</p> <p>135° POST</p> <p><b>PART# 135° POST</b></p>	 <p>(DETAIL # 23)</p> <p>EXPANSION MULLION OR SPECIAL CORNERS GASKET AVAILABLE</p> <p><b>PART# EM200</b></p>	 <p>(DETAIL # 24)</p> <p>CENTER HUNG DOOR JAMB</p> <p><b>PART# J251</b></p>
<p>CLEAR 24' 1" _____.00</p> <p>BRONZE 24' 1" _____.00</p>	<p>CLEAR 24' 1" _____.00</p> <p>BRONZE 24' 1" _____.00</p>	<p>CLEAR 24' 1" _____.00</p> <p>BRONZE 24' 1" _____.00</p>	<p>CLEAR 24' 1" _____.00</p> <p>BRONZE 24' 1" _____.00</p>

CASCADE ALUMINUM, INC. HAS NO CONTROL OVER THE USE OF IT'S PRODUCTS.  
THE OWNER, THE ARCHITECT AND THE INSTALLER ARE RESPONSIBLE FOR THE SELECTION OF  
THE PROPER SYSTEMS AND SIZES TO COMPLY WITH ALL APPLICABLE BUILDING AND SAFETY LAWS.







# CASCADE ALUMINUM, INC.

ENTRANCES, EXTRUSIONS & ANODIZING

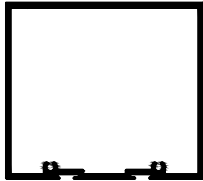
## SERIES # 450-CS 2" x 4 1/2" CENTER GLAZE

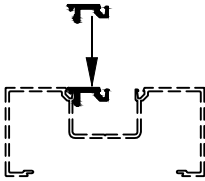
1" INSULATED GLASS SYSTEM FOR INTERIOR AND EXTERIOR GLAZING

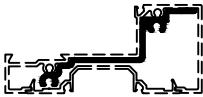
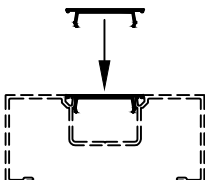
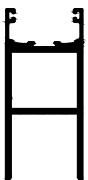
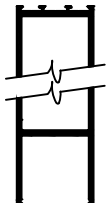
### QUARTER SIZE DETAILS

 <p>(DETAIL # 25) 2" x 4 1/2" TUBE <b>PART# T450</b></p>	 <p>(DETAIL # 26) 4" x 4 1/2" TUBE <b>PART# 4" x 4 1/2"</b></p>	 <p>(DETAIL # 27) TRANSOM SASH WITH STOP <b>PART# TS450/ST</b></p>	 <p>(DETAIL # 28) FLAT FILLER <b>PART# FF200</b></p>
<p>CLEAR 24' 1" _____.00 BRONZE 24' 1" _____.00</p>	<p>CLEAR 18' 0" _____.00 BRONZE 18' 0" _____.00</p>	<p>CLEAR 24' 1" _____.00 BRONZE 24' 1" _____.00</p>	<p>MILL 24' 1" _____.00 CLEAR 24' 1" _____.00 BRONZE 24' 1" _____.00</p>
 <p>(DETAIL # 29) ADAPTER TO CONVERT TO 1/4" GLAZING <b>PART# AD1</b></p>	 <p>(DETAIL # 30) TOPLOAD DOOR STOP <b>PART# TL DS100</b></p>	 <p>(DETAIL # 31) SIDELOAD DOOR STOP <b>PART# SL DS100</b></p>	 <p>(DETAIL # 32) HORIZONTAL CLIP JOINT <b>PART# HC200</b></p>
<p>CLEAR 24' 1" _____.00 BRONZE 24' 1" _____.00</p>	<p>CLEAR 21'-2" _____.00 BRONZE 21'-2" _____.00</p>	<p>CLEAR 21'-2" _____.00 BRONZE 21'-2" _____.00</p>	<p>CLEAR 1 1/4" _____.00 BRONZE 1 1/4" _____.00</p>
 <p>(DETAIL # 33) REGLET FILLER <b>PART# RF100</b></p>	 <p>(DETAIL # 34) 4" BULKHEAD WITH STOP <b>PART# BR802</b></p>	 <p>(DETAIL # 35) 6 1/4" BULKHEAD WITH STOP <b>PART# WSTR</b></p>	 <p>(DETAIL # 36) 10 1/4" BULKHEAD WITH STOP <b>PART# 9 1/2"BR</b></p>
<p>CLEAR 24' 1" _____.00 BRONZE 24' 1" _____.00</p>	<p>CLEAR 21'-6" _____.00 BRONZE 21'-6" _____.00</p>	<p>CLEAR 19'-8" _____.00 BRONZE 19'-8" _____.00</p>	<p>CLEAR 21'-6" _____.00 BRONZE 21'-6" _____.00</p>

CASCADE ALUMINUM, INC. HAS NO CONTROL OVER THE USE OF IT'S PRODUCTS.  
THE OWNER, THE ARCHITECT AND THE INSTALLER ARE RESPONSIBLE FOR THE SELECTION OF  
THE PROPER SYSTEMS AND SIZES TO COMPLY WITH ALL APPLICABLE BUILDING AND SAFETY LAWS.

# CASCADE ALUMINUM, INC.

ENTRANCES, EXTRUSIONS & ANODIZING

## SERIES # 450-CS 2" x 4 1/2" CENTER GLAZE

1" INSULATED GLASS SYSTEM FOR INTERIOR AND EXTERIOR GLAZING

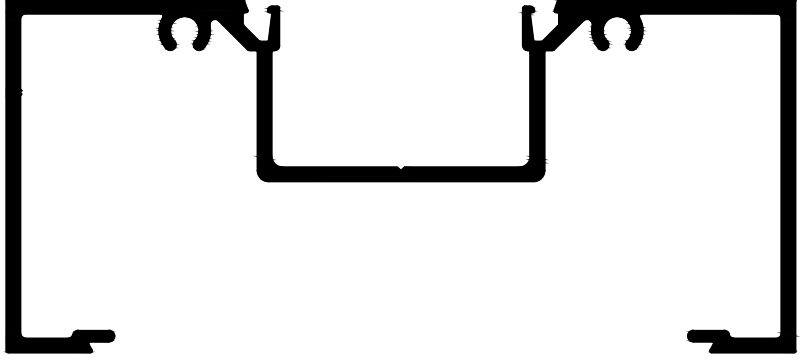
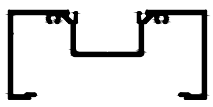
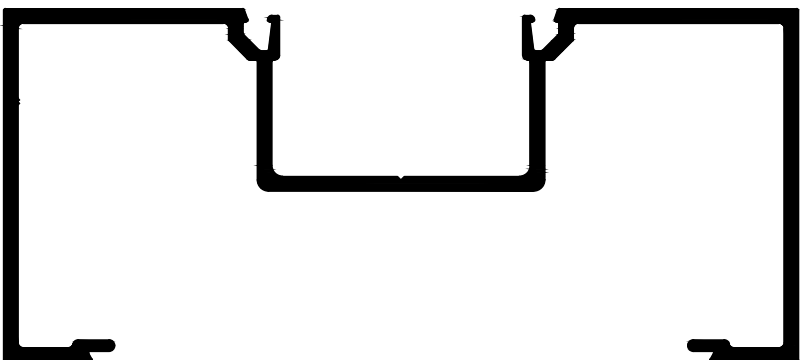
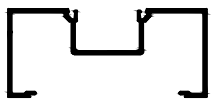
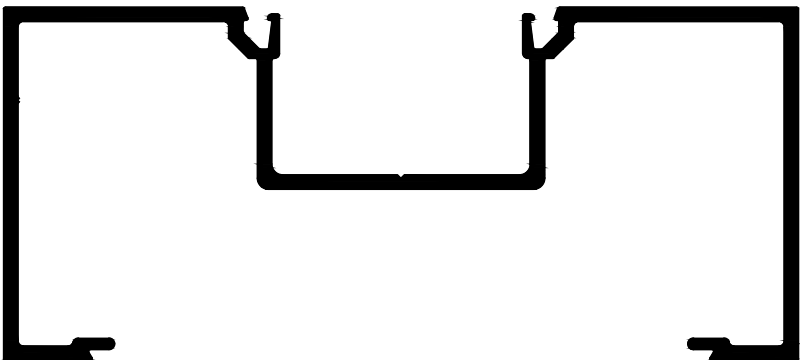
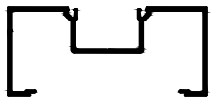
FULL SIZE DETAILS	DETAIL NUMBER	QUARTER SIZE DETAILS
	1	 (DETAIL # 1) VERTICAL OR HEAD  <b>PART# V452</b>  AVAILABLE IN 24' 1" LENGTH
	2	 (DETAIL # 2) VERTICAL NO SPLINE  <b>PART# V452R</b>  AVAILABLE IN 24' 1" LENGTHS
	3	 (DETAIL # 3) VERTICAL NO SPLINE  <b>PART# V452R</b>  AVAILABLE IN 20'-0" & 21'-7" LENGTHS





CASCADE ALUMINUM, INC. HAS NO CONTROL OVER THE USE OF IT'S PRODUCTS.  
 THE OWNER, THE ARCHITECT AND THE INSTALLER ARE RESPONSIBLE FOR THE SELECTION OF  
 THE PROPER SYSTEMS AND SIZES TO COMPLY WITH ALL APPLICABLE BUILDING AND SAFETY LAWS.

# CASCADE ALUMINUM, INC.

ENTRANCES, EXTRUSIONS & ANODIZING

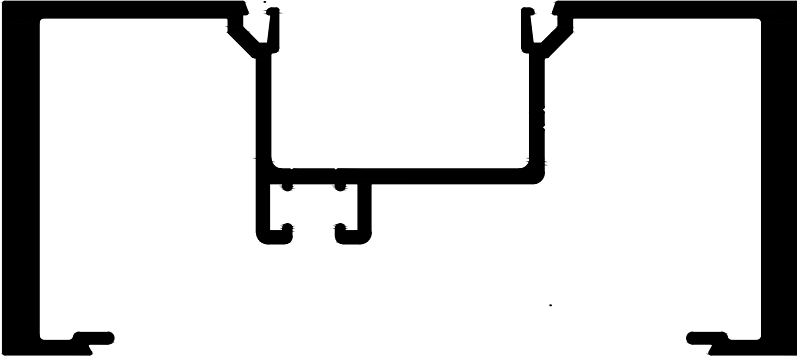
## SERIES # 450-CS 2" x 4 1/2" CENTER GLAZE

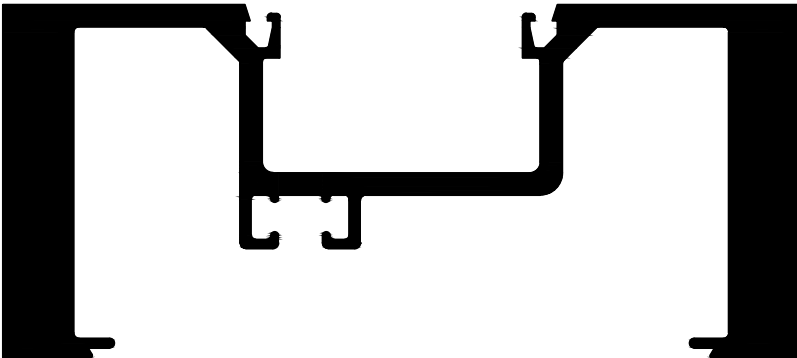
1" INSULATED GLASS SYSTEM FOR INTERIOR AND EXTERIOR GLAZING

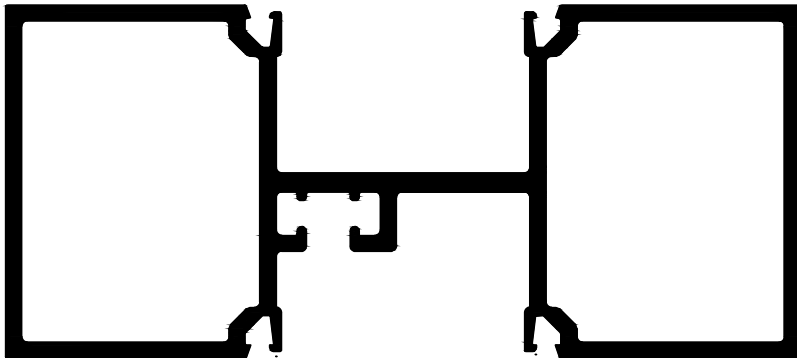
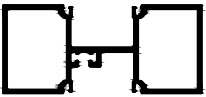
FULL SIZE DETAILS	DETAIL NUMBER	QUARTER SIZE DETAILS
	4	 <p>(DETAIL # 4)</p> <p>INTERMEDIATE VERTICAL</p> <p><b>PART# IV452</b></p> <hr/> <p>AVAILABLE IN 24' 1" LENGTH</p>
	5	 <p>(DETAIL # 5)</p> <p>HEAVY WALL VERTICAL</p> <p><b>PART# H452</b></p> <hr/> <p>AVAILABLE IN 15'-6" LENGTH</p>
	6	 <p>(DETAIL # 6)</p> <p>ONE PIECE VERTICAL</p> <p><b>PART# V215</b></p> <hr/> <p>AVAILABLE IN 24' 1" LENGTH</p>





CASCADE ALUMINUM, INC. HAS NO CONTROL OVER THE USE OF IT'S PRODUCTS.  
THE OWNER, THE ARCHITECT AND THE INSTALLER ARE RESPONSIBLE FOR THE SELECTION OF  
THE PROPER SYSTEMS AND SIZES TO COMPLY WITH ALL APPLICABLE BUILDING AND SAFETY LAWS.

# CASCADE ALUMINUM, INC.

ENTRANCES, EXTRUSIONS & ANODIZING

## SERIES # 450-CS 2" x 4 1/2" CENTER GLAZE

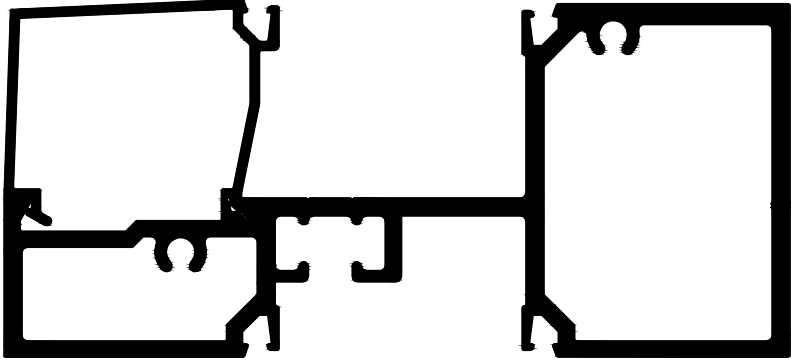
1" INSULATED GLASS SYSTEM FOR INTERIOR AND EXTERIOR GLAZING

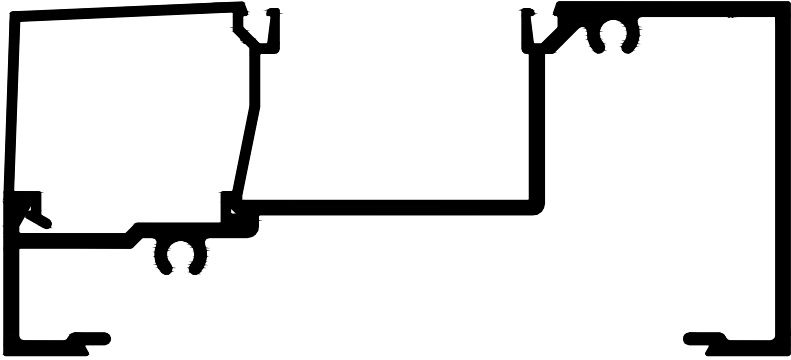
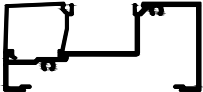
FULL SIZE DETAILS	DETAIL NUMBER	QUARTER SIZE DETAILS
	7	 (DETAIL # 7) POCKET FILLER  <b>PART# IF200</b>  AVAILABLE IN 24' 1" LENGTH
	8	 (DETAIL # 8) INTERMEDIATE HORIZONTAL  <b>PART# H450/ST</b>  AVAILABLE IN 24' 1" LENGTH
	9	 (DETAIL # 9) SILL OR INTERMEDIATE HORIZONTAL WITH IF200  <b>PART# H200/ST</b>  AVAILABLE IN 24' 1" LENGTH



CASCADE ALUMINUM, INC. HAS NO CONTROL OVER THE USE OF IT'S PRODUCTS.  
 THE OWNER, THE ARCHITECT AND THE INSTALLER ARE RESPONSIBLE FOR THE SELECTION OF  
 THE PROPER SYSTEMS AND SIZES TO COMPLY WITH ALL APPLICABLE BUILDING AND SAFETY LAWS.

# CASCADE ALUMINUM, INC.

ENTRANCES, EXTRUSIONS & ANODIZING

## SERIES # 450-CS 2" x 4 1/2" CENTER GLAZE

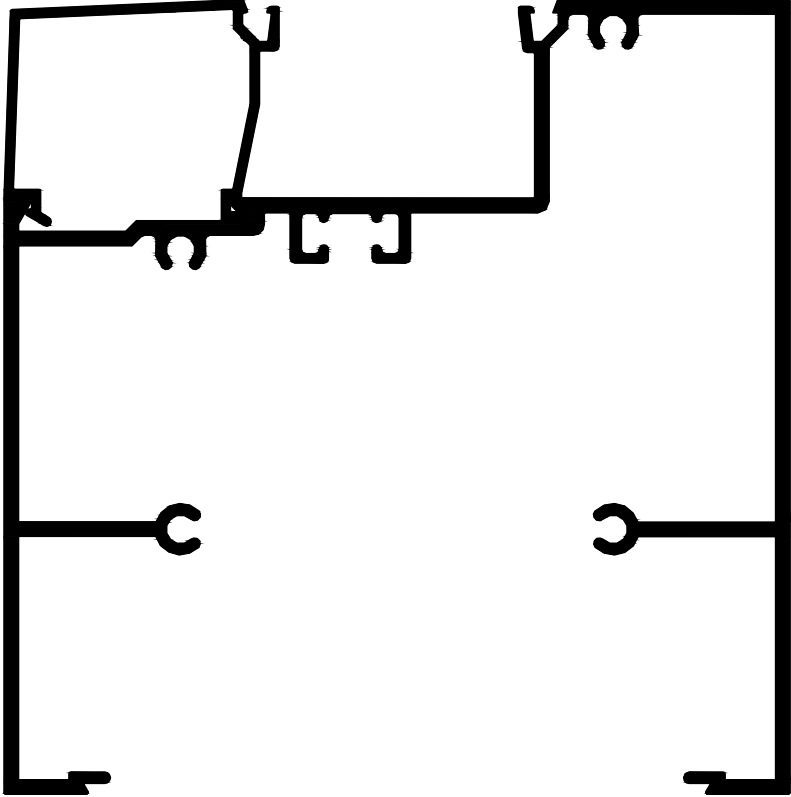
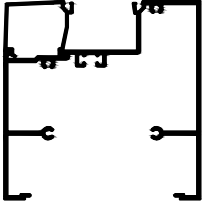
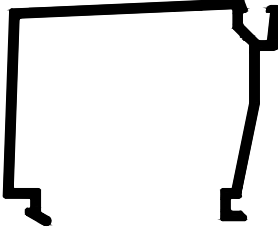
1" INSULATED GLASS SYSTEM FOR INTERIOR AND EXTERIOR GLAZING

FULL SIZE DETAILS	DETAIL NUMBER	QUARTER SIZE DETAILS
	<p><b>10</b></p>	 <p>( <b>DETAIL # 10</b> )</p> <p>4 1/2" x 4 1/2" SILL OR INTERMEDIATE HORIZONTAL WITH IF200</p> <p><b>PART# IB200/ST</b></p> <p>AVAILABLE IN 24' 1" LENGTH</p>
	<p><b>11</b></p>	 <p>( <b>DETAIL # 11</b> )</p> <p>GLASS STOP FOR H200, H450, IB200 AND SI450</p> <p><b>PART# HS450</b></p> <p>AVAILABLE IN 24' 1" LENGTH</p>





CASCADE ALUMINUM, INC. HAS NO CONTROL OVER THE USE OF IT'S PRODUCTS.  
THE OWNER, THE ARCHITECT AND THE INSTALLER ARE RESPONSIBLE FOR THE SELECTION OF  
THE PROPER SYSTEMS AND SIZES TO COMPLY WITH ALL APPLICABLE BUILDING AND SAFETY LAWS.

# CASCADE ALUMINUM, INC.

ENTRANCES, EXTRUSIONS & ANODIZING

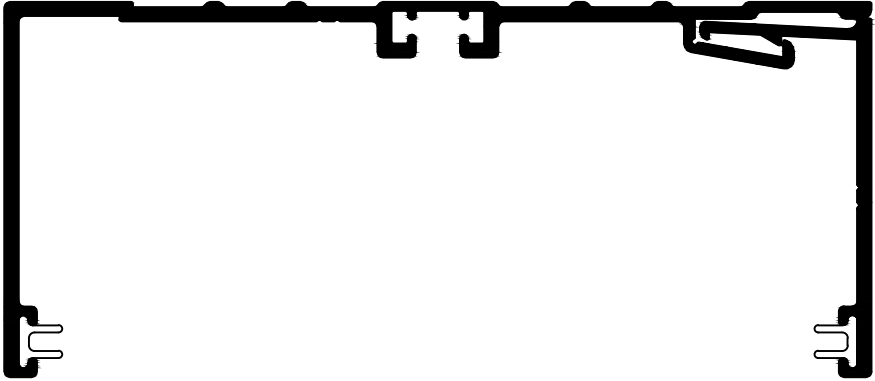
## SERIES # 450-CS 2" x 4 1/2" CENTER GLAZE

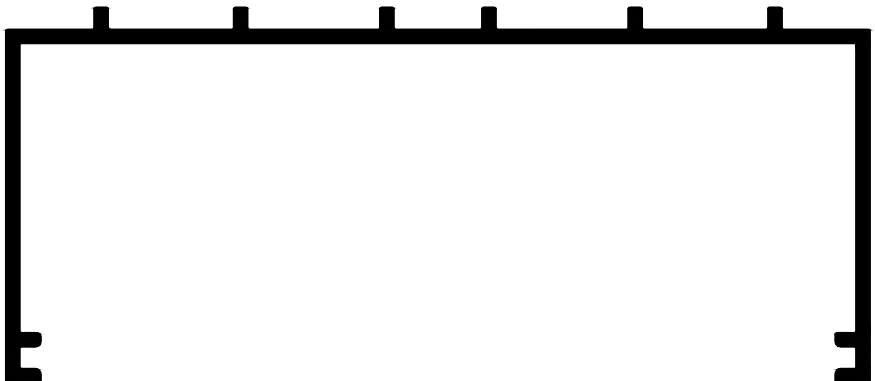
1" INSULATED GLASS SYSTEM FOR INTERIOR AND EXTERIOR GLAZING

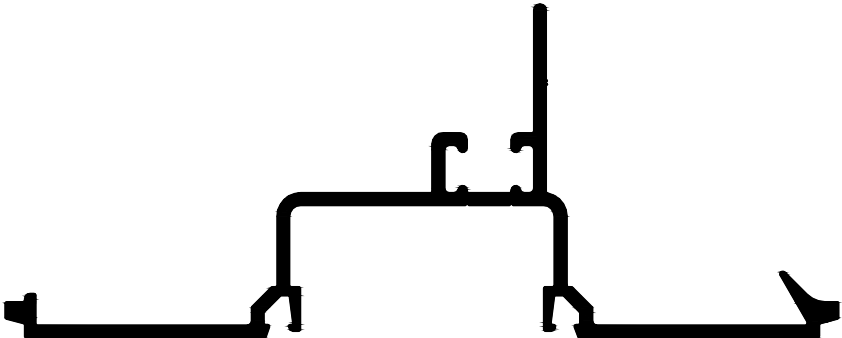
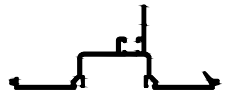
FULL SIZE DETAILS	DETAIL NUMBER	QUARTER SIZE DETAILS
	<p><b>12</b></p>	 <p>(DETAIL # 12) TWO PIECE COMPENSATION CHANNEL INCLUDES GASKET <b>PART# CC450/ST</b></p> <p>AVAILABLE IN 24' 1"LENGTH</p>
	<p><b>13</b></p>	 <p>(DETAIL # 13) HEAD CAN OR COMPENSATION CHANNEL <b>PART# IHC450</b></p> <p>AVAILABLE IN 24' 1"LENGTH</p>
	<p><b>14</b></p>	 <p>(DETAIL # 14) HEAD CAN INSERT <b>PART# IHI450</b></p> <p>AVAILABLE IN 24' 1"LENGTH</p>

CASCADE ALUMINUM, INC. HAS NO CONTROL OVER THE USE OF IT'S PRODUCTS.  
THE OWNER, THE ARCHITECT AND THE INSTALLER ARE RESPONSIBLE FOR THE SELECTION OF  
THE PROPER SYSTEMS AND SIZES TO COMPLY WITH ALL APPLICABLE BUILDING AND SAFETY LAWS.







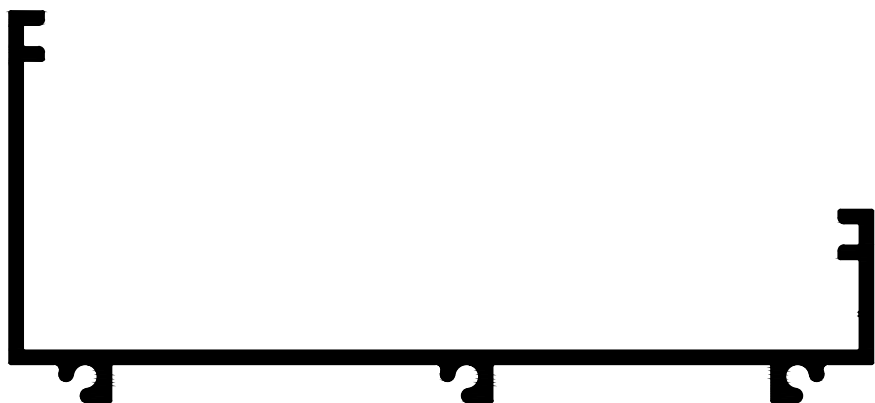

# CASCADE ALUMINUM, INC.

ENTRANCES, EXTRUSIONS & ANODIZING

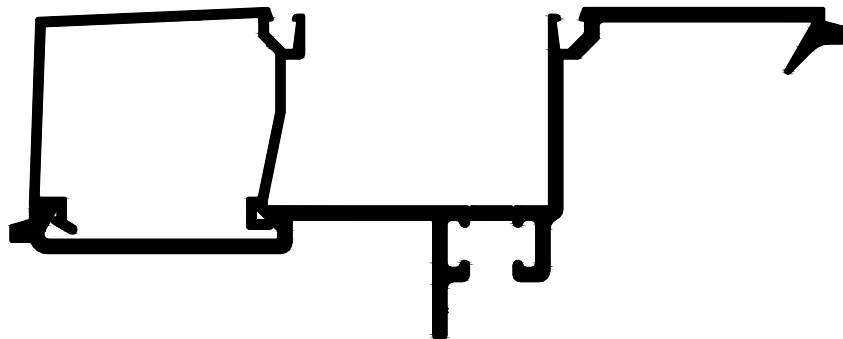
## SERIES # 450-CS 2" x 4 1/2" CENTER GLAZE

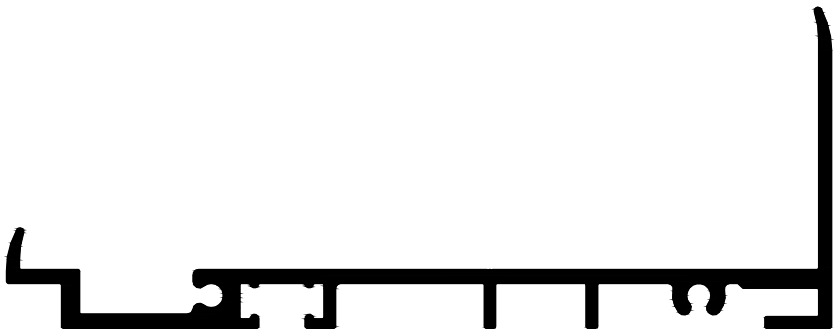
1" INSULATED GLASS SYSTEM FOR INTERIOR AND EXTERIOR GLAZING

FULL SIZE DETAILS	DETAIL NUMBER	QUARTER SIZE DETAILS
	<p><b>15</b></p>	 <p>(DETAIL # 15)</p> <p>SILL CAN</p> <p><b>PART# SC450</b></p> <hr/> <p>AVAILABLE IN 24' 1"LENGTH</p>
	<p><b>16</b></p>	 <p>(DETAIL # 16)</p> <p>SILL CAN INSERT WITH STOP</p> <p><b>PART# SI450/ST</b></p> <hr/> <p>AVAILABLE IN 24' 1"LENGTH</p>
	<p><b>17</b></p>	 <p>(DETAIL # 17)</p> <p>SILL FLASHING</p> <p><b>PART# SF200</b></p> <hr/> <p>AVAILABLE IN 24' 1"LENGTH</p>



CASCADE ALUMINUM, INC. HAS NO CONTROL OVER THE USE OF IT'S PRODUCTS.  
THE OWNER, THE ARCHITECT AND THE INSTALLER ARE RESPONSIBLE FOR THE SELECTION OF  
THE PROPER SYSTEMS AND SIZES TO COMPLY WITH ALL APPLICABLE BUILDING AND SAFETY LAWS.

# CASCADE ALUMINUM, INC.

ENTRANCES, EXTRUSIONS & ANODIZING

## SERIES # 450-CS 2" x 4 1/2" CENTER GLAZE

1" INSULATED GLASS SYSTEM FOR INTERIOR AND EXTERIOR GLAZING

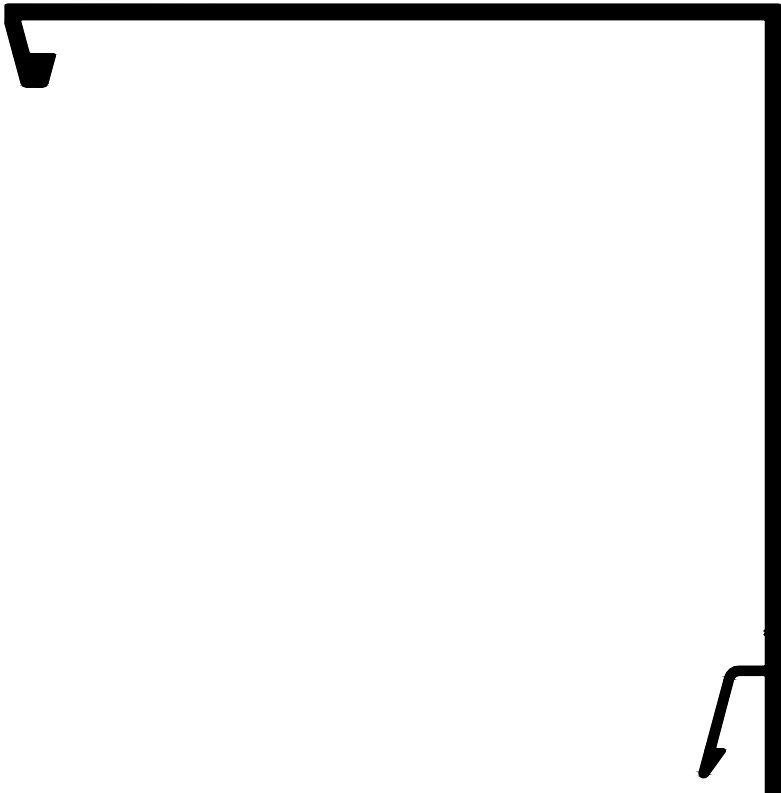
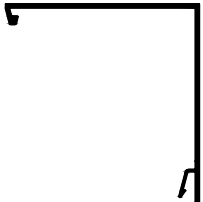
FULL SIZE DETAILS	DETAIL NUMBER	QUARTER SIZE DETAILS
	<p><b>18</b></p>	 <p>(DETAIL # 18) SILL FLASHING</p> <p><b>PART# SF100</b></p> <p>AVAILABLE IN 24' 1"LENGTH</p>
	<p><b>19</b></p>	 <p>(DETAIL # 19) CORNER POST BEAUTY CAP</p> <p><b>PART# CP450</b></p> <p>AVAILABLE IN 24' 1"LENGTH</p>



CASCADE ALUMINUM, INC. HAS NO CONTROL OVER THE USE OF IT'S PRODUCTS.  
THE OWNER, THE ARCHITECT AND THE INSTALLER ARE RESPONSIBLE FOR THE SELECTION OF  
THE PROPER SYSTEMS AND SIZES TO COMPLY WITH ALL APPLICABLE BUILDING AND SAFETY LAWS.

# CASCADE ALUMINUM, INC.

ENTRANCES, EXTRUSIONS & ANODIZING

## SERIES # 450-CS 2" x 4 1/2" CENTER GLAZE

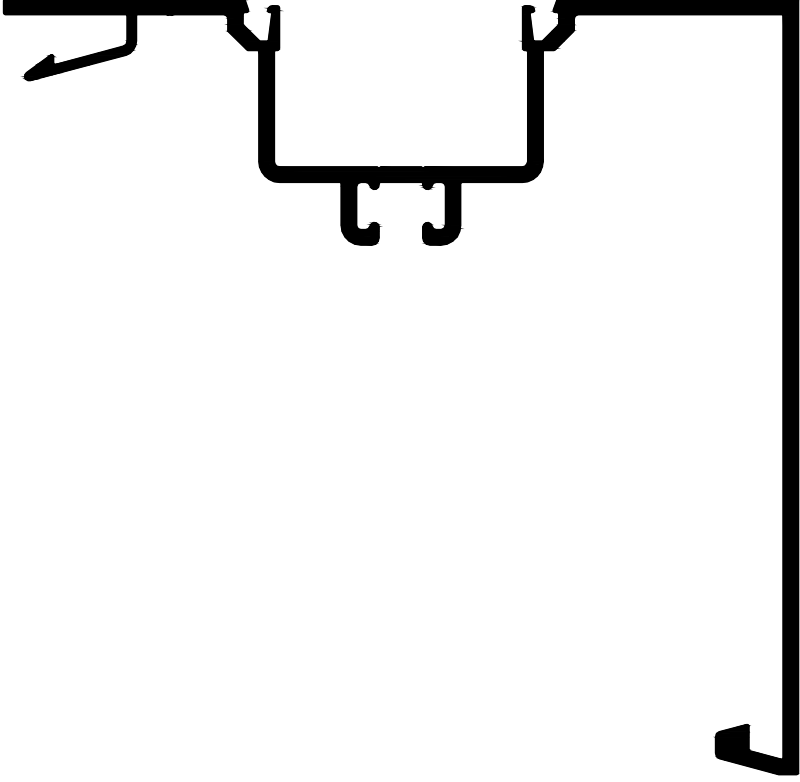
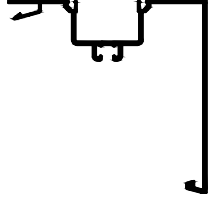
1" INSULATED GLASS SYSTEM FOR INTERIOR AND EXTERIOR GLAZING

FULL SIZE DETAILS	DETAIL NUMBER	QUARTER SIZE DETAILS
	<p><b>20</b></p>	 <p>( <b>DETAIL # 20</b> )</p> <p>SINGLE POCKET CORNER POST</p> <p><b>PART# CP451</b></p> <p>AVAILABLE IN 24' 1" LENGTH</p>
	<p><b>23</b></p>	 <p>( <b>DETAIL # 23</b> )</p> <p>EXPANSION MULLION OR SPECIAL CORNERS GASKET AVAILABLE</p> <p><b>PART# EM200</b></p> <p>AVAILABLE IN 24' 1" LENGTH</p>



CASCADE ALUMINUM, INC. HAS NO CONTROL OVER THE USE OF IT'S PRODUCTS.  
THE OWNER, THE ARCHITECT AND THE INSTALLER ARE RESPONSIBLE FOR THE SELECTION OF  
THE PROPER SYSTEMS AND SIZES TO COMPLY WITH ALL APPLICABLE BUILDING AND SAFETY LAWS.

# CASCADE ALUMINUM, INC.

ENTRANCES, EXTRUSIONS & ANODIZING

## SERIES # 450-CS 2" x 4 1/2" CENTER GLAZE

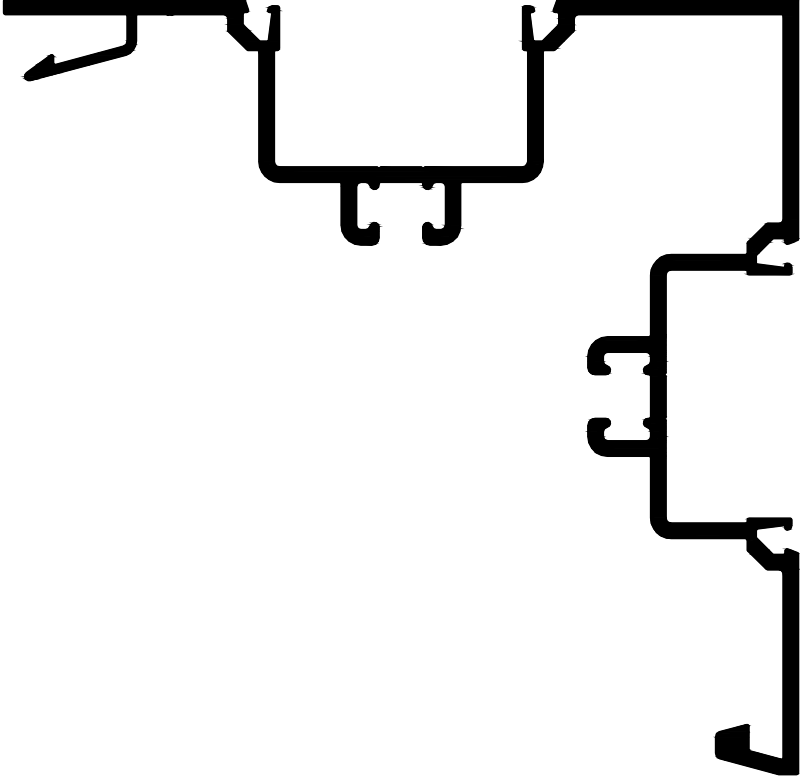
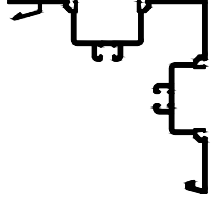
1" INSULATED GLASS SYSTEM FOR INTERIOR AND EXTERIOR GLAZING

FULL SIZE DETAILS	DETAIL NUMBER	QUARTER SIZE DETAILS
	<p>21</p>	 <p>(DETAIL # 21) DOUBLE POCKET CORNER POST</p> <p><b>PART# CP452</b></p> <p>AVAILABLE IN 24' 1" LENGTH</p>
	<p>24</p>	 <p>(DETAIL # 24) CENTER HUNG DOOR JAMB</p> <p><b>PART# J251</b></p> <p>AVAILABLE IN 24' 1" LENGTH</p>

CASCADE ALUMINUM, INC. HAS NO CONTROL OVER THE USE OF IT'S PRODUCTS.  
THE OWNER, THE ARCHITECT AND THE INSTALLER ARE RESPONSIBLE FOR THE SELECTION OF  
THE PROPER SYSTEMS AND SIZES TO COMPLY WITH ALL APPLICABLE BUILDING AND SAFETY LAWS.

# CASCADE ALUMINUM, INC.

ENTRANCES, EXTRUSIONS & ANODIZING

## SERIES # 450-CS 2" x 4 1/2" CENTER GLAZE

1" INSULATED GLASS SYSTEM FOR INTERIOR AND EXTERIOR GLAZING

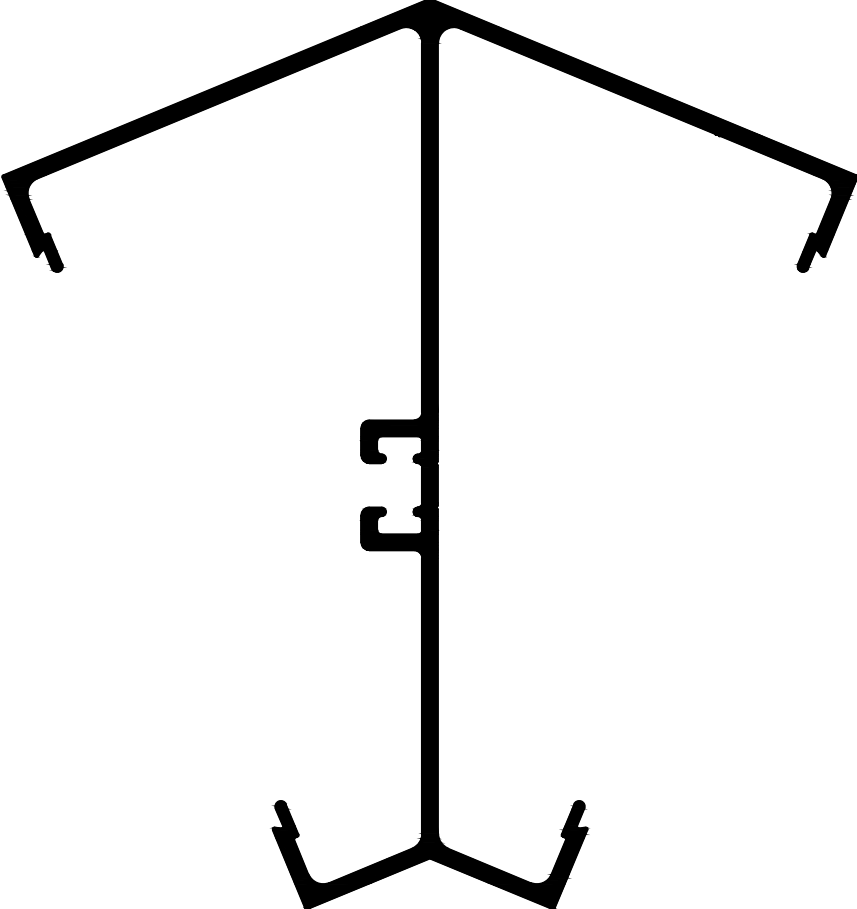
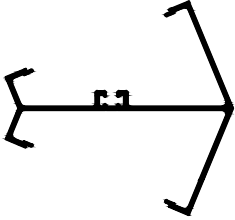
FULL SIZE DETAILS	DETAIL NUMBER	QUARTER SIZE DETAILS
	<b>22</b>	 <p>(DETAIL # 22) 135° POST</p> <p><b>PART# 135° POST</b></p> <p>AVAILABLE IN 24' 1" LENGTH</p>



CASCADE ALUMINUM, INC. HAS NO CONTROL OVER THE USE OF IT'S PRODUCTS.  
THE OWNER, THE ARCHITECT AND THE INSTALLER ARE RESPONSIBLE FOR THE SELECTION OF  
THE PROPER SYSTEMS AND SIZES TO COMPLY WITH ALL APPLICABLE BUILDING AND SAFETY LAWS.

# CASCADE ALUMINUM, INC.

ENTRANCES, EXTRUSIONS & ANODIZING

## SERIES # 450-CS 2" x 4 1/2" CENTER GLAZE

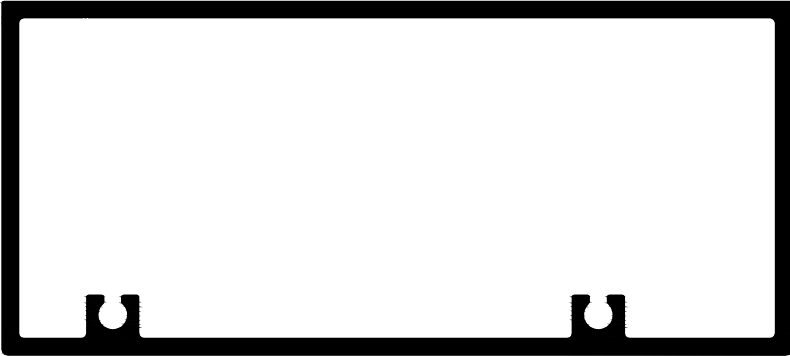
1" INSULATED GLASS SYSTEM FOR INTERIOR AND EXTERIOR GLAZING

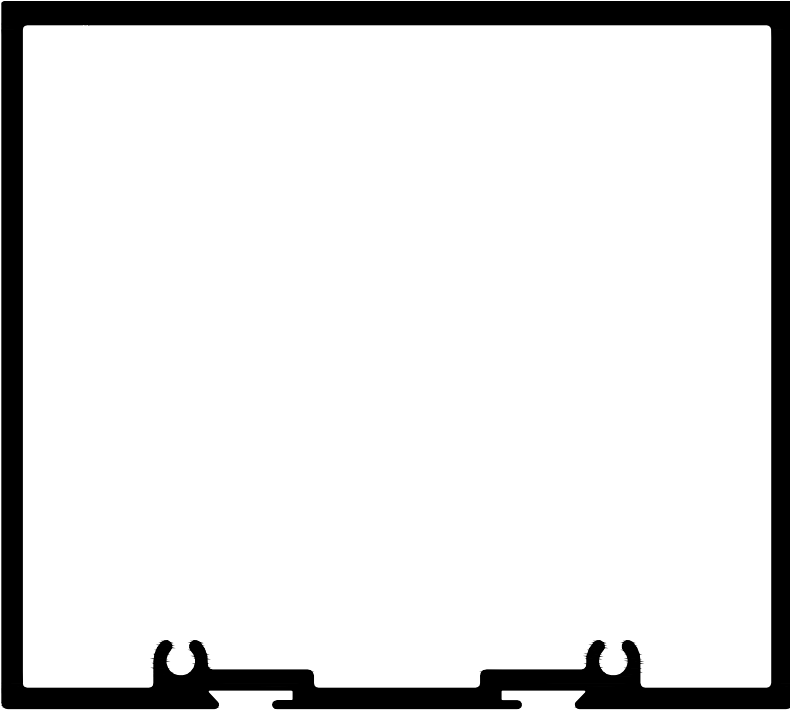
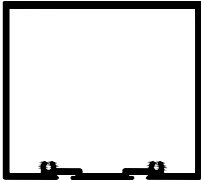
FULL SIZE DETAILS	DETAIL NUMBER	QUARTER SIZE DETAILS
	<p><b>25</b></p>	 <p>(DETAIL # 25)</p> <p>2" x 4 1/2" TUBE</p> <p><b>PART# T450</b></p> <p>AVAILABLE IN 24' 1" LENGTH</p>
	<p><b>26</b></p>	 <p>(DETAIL # 26)</p> <p>4" x 4 1/2" TUBE</p> <p><b>PART# 4" x 4 1/2"</b></p> <p>AVAILABLE IN 18'-0" LENGTH</p>







CASCADE ALUMINUM, INC. HAS NO CONTROL OVER THE USE OF IT'S PRODUCTS.  
 THE OWNER, THE ARCHITECT AND THE INSTALLER ARE RESPONSIBLE FOR THE SELECTION OF  
 THE PROPER SYSTEMS AND SIZES TO COMPLY WITH ALL APPLICABLE BUILDING AND SAFETY LAWS.

# CASCADE ALUMINUM, INC.

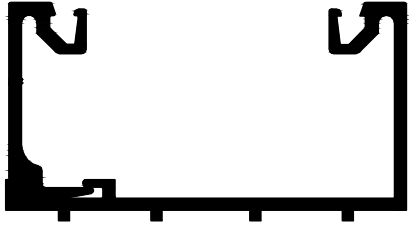
ENTRANCES, EXTRUSIONS & ANODIZING

## SERIES # 450-CS 2" x 4 1/2" CENTER GLAZE

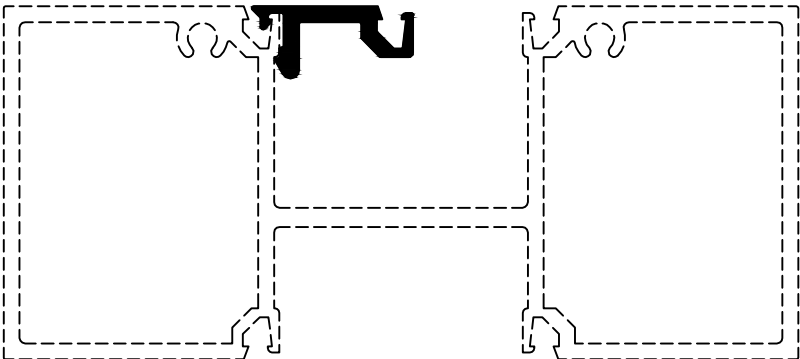
1" INSULATED GLASS SYSTEM FOR INTERIOR AND EXTERIOR GLAZING

FULL SIZE DETAILS	DETAIL NUMBER	QUARTER SIZE DETAILS
	<p><b>27</b></p>	 <p>( <b>DETAIL # 27</b> )</p> <p>TRANSOM SASH WITH STOP</p> <p><b>PART# TS450/ST</b></p> <p>AVAILABLE IN 24' 1"LENGTH</p>
	<p><b>28</b></p>	 <p>( <b>DETAIL # 28</b> )</p> <p>FLAT FILLER</p> <p><b>PART# FF200</b></p> <p>AVAILABLE IN 24' 1"LENGTH</p>
	<p><b>29</b></p>	 <p>( <b>DETAIL # 29</b> )</p> <p>ADAPTER TO CONVERT TO 1/4" GLAZING</p> <p><b>PART# AD1</b></p> <p>AVAILABLE IN 24' 1"LENGTH</p>







CASCADE ALUMINUM, INC. HAS NO CONTROL OVER THE USE OF IT'S PRODUCTS.  
THE OWNER, THE ARCHITECT AND THE INSTALLER ARE RESPONSIBLE FOR THE SELECTION OF  
THE PROPER SYSTEMS AND SIZES TO COMPLY WITH ALL APPLICABLE BUILDING AND SAFETY LAWS.

# CASCADE ALUMINUM, INC.

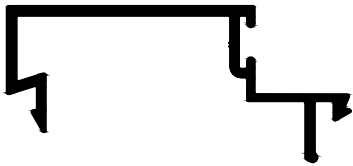
ENTRANCES, EXTRUSIONS & ANODIZING

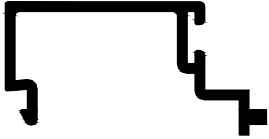
## SERIES # 450-CS 2" x 4 1/2" CENTER GLAZE

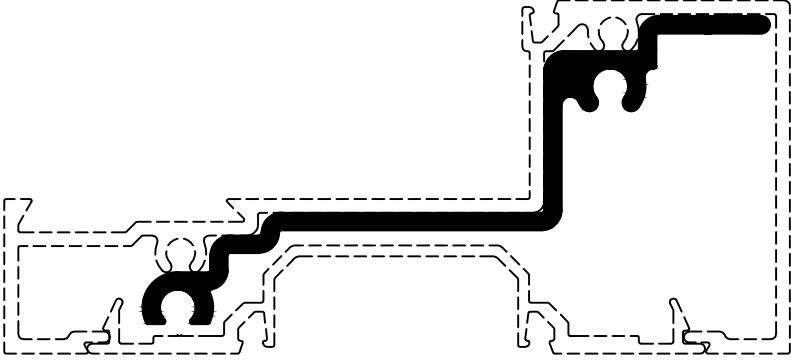
1" INSULATED GLASS SYSTEM FOR INTERIOR AND EXTERIOR GLAZING

FULL SIZE DETAILS	DETAIL NUMBER	QUARTER SIZE DETAILS
	<b>30</b>	 <p>(DETAIL # 30)</p> <p>TOPLOAD DOOR STOP</p> <p><b>PART# TL DS100</b></p> <p>AVAILABLE IN 21'-2" LENGTH</p>
	<b>31</b>	 <p>(DETAIL # 31)</p> <p>SIDELOAD DOOR STOP</p> <p><b>PART# SL DS100</b></p> <p>AVAILABLE IN 21'-2" LENGTH</p>
	<b>32</b>	 <p>(DETAIL # 32)</p> <p>HORIZONTAL CLIP JOINT</p> <p><b>PART# HC200</b></p> <p>AVAILABLE IN 1 1/4" LENGTH</p>

CASCADE ALUMINUM, INC. HAS NO CONTROL OVER THE USE OF IT'S PRODUCTS.  
 THE OWNER, THE ARCHITECT AND THE INSTALLER ARE RESPONSIBLE FOR THE SELECTION OF  
 THE PROPER SYSTEMS AND SIZES TO COMPLY WITH ALL APPLICABLE BUILDING AND SAFETY LAWS.





# CASCADE ALUMINUM, INC.

ENTRANCES, EXTRUSIONS & ANODIZING

## SERIES # 450-CS 2" x 4 1/2" CENTER GLAZE

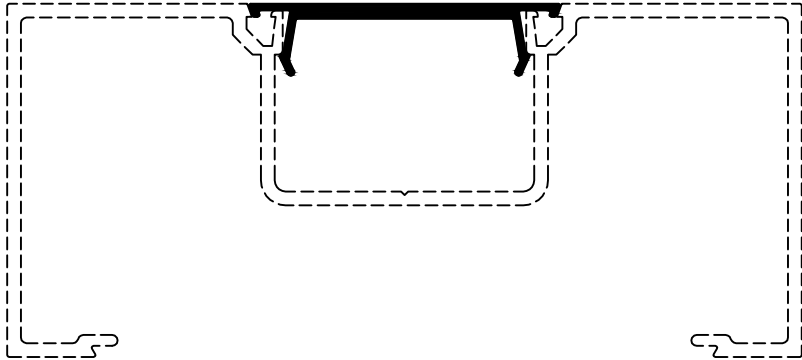
1" INSULATED GLASS SYSTEM FOR INTERIOR AND EXTERIOR GLAZING

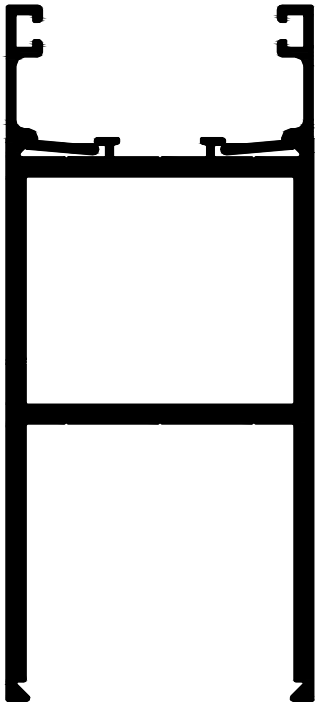
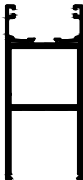
FULL SIZE DETAILS	DETAIL NUMBER	QUARTER SIZE DETAILS
	<p><b>33</b></p>	<div style="text-align: center;">  </div> <p>(DETAIL # 33) REGLET FILLER</p> <p><b>PART# RF100</b></p> <hr/> <p>AVAILABLE IN 24' 1" LENGTH</p>
	<p><b>34</b></p>	<div style="text-align: center;">  </div> <p>(DETAIL # 34) 4" BULKHEAD WITH STOP</p> <p><b>PART# BR802</b></p> <hr/> <p>AVAILABLE IN 21'-6" LENGTH</p>

CASCADE ALUMINUM, INC. HAS NO CONTROL OVER THE USE OF IT'S PRODUCTS.  
THE OWNER, THE ARCHITECT AND THE INSTALLER ARE RESPONSIBLE FOR THE SELECTION OF  
THE PROPER SYSTEMS AND SIZES TO COMPLY WITH ALL APPLICABLE BUILDING AND SAFETY LAWS.

# CASCADE ALUMINUM, INC.

ENTRANCES, EXTRUSIONS & ANODIZING

## SERIES # 450-CS 2" x 4 1/2" CENTER GLAZE

1" INSULATED GLASS SYSTEM FOR INTERIOR AND EXTERIOR GLAZING

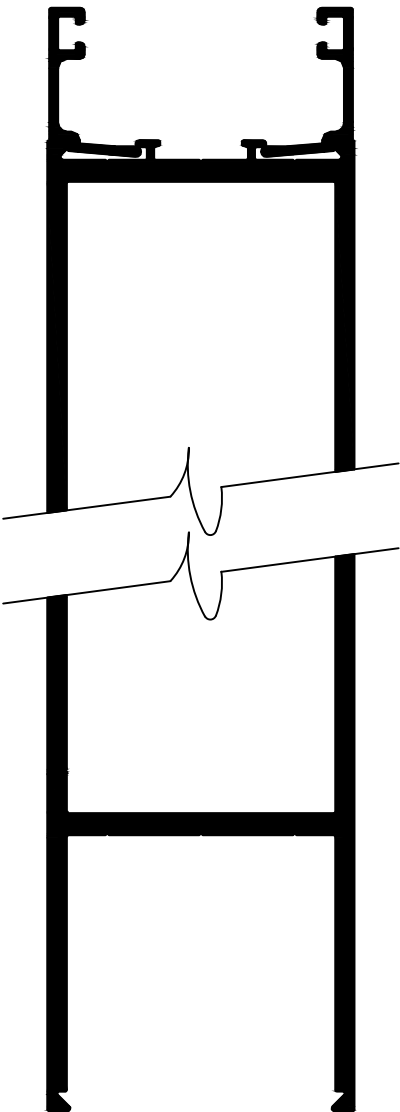
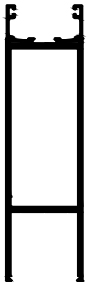
FULL SIZE DETAILS	DETAIL NUMBER	QUARTER SIZE DETAILS
	<h3>35</h3>	 <p>( DETAIL # 35 )</p> <p>6 1/4" BULKHEAD WITH STOP</p> <p><b>PART# WSTR</b></p> <p>AVAILABLE IN 19'-8" LENGTH</p>
		<h3>36</h3>

CASCADE ALUMINUM, INC. HAS NO CONTROL OVER THE USE OF IT'S PRODUCTS.  
 THE OWNER, THE ARCHITECT AND THE INSTALLER ARE RESPONSIBLE FOR THE SELECTION OF  
 THE PROPER SYSTEMS AND SIZES TO COMPLY WITH ALL APPLICABLE BUILDING AND SAFETY LAWS.