









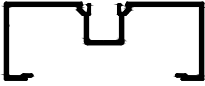

# CASCADE ALUMINUM, INC.

ENTRANCES, EXTRUSIONS & ANODIZING

## SERIES # 150 1 3/4" x 4 1/2" CENTER GLAZE

1" INSULATED GLASS SYSTEM FOR INTERIOR AND EXTERIOR GLAZING

### QUARTER SIZE DETAILS

 <p>(DETAIL # 1) VERTICAL OR HEAD</p> <p><b>PART# V152</b></p>	 <p>(DETAIL # 2) VERTICAL NO SPLINE</p> <p><b>PART# V157</b></p>	 <p>(DETAIL # 3) VERTICAL NO SPLINE</p> <p><b>PART# V157</b></p>	 <p>(DETAIL # 4) POCKET FILLER</p> <p><b>PART# F100</b></p>
<p>CLEAR 24'-1" _____.00 BRONZE 24'-1" _____.00</p>	<p>CLEAR 24'-1" _____.00 BRONZE 24'-1" _____.00</p>	<p>CLEAR 21'-7" _____.00 BRONZE 21'-7" _____.00</p>	<p>CLEAR 24'-1" _____.00 BRONZE 24'-1" _____.00</p>
 <p>(DETAIL # 5) SILL OR INTERMEDIATE HORIZONTAL WHEN USED WITH F100</p> <p><b>PART# H153/ST</b></p>	 <p>(DETAIL # 6) TWO PIECE COMPENSATION CHANNEL INCLUDES GASKET</p> <p><b>PART# CC450/ST</b></p>	 <p>(DETAIL # 7) 2"x4 1/2" COMPENSATION CHANNEL OR HEAD CAN</p> <p><b>PART# IHC450</b></p>	 <p>(DETAIL # 8) HEAD CAN INSERT</p> <p><b>PART# HI221</b></p>
<p>CLEAR 24'-1" _____.00 BRONZE 24'-1" _____.00</p>	<p>CLEAR 24'-1" _____.00 BRONZE 24'-1" _____.00</p>	<p>CLEAR 24'-1" _____.00 BRONZE 24'-1" _____.00</p>	<p>CLEAR 24'-1" _____.00 BRONZE 24'-1" _____.00</p>
 <p>(DETAIL # 9) SILL CAN</p> <p><b>PART# S222</b></p>	 <p>(DETAIL # 10) SILL CAN INSERT WITH STOP</p> <p><b>PART# SI223/ST</b></p>	 <p>(DETAIL # 11) GLASS STOP FOR H153, S1223</p> <p><b>PART# HS153</b></p>	 <p>(DETAIL # 12) FLAT FILLER</p> <p><b>PART# FF200</b></p>
<p>CLEAR 24'-1" _____.00 BRONZE 24'-1" _____.00</p>	<p>CLEAR 24'-1" _____.00 BRONZE 24'-1" _____.00</p>	<p>CLEAR 24'-1" _____.00 BRONZE 24'-1" _____.00</p>	<p>MILL 24'-1" _____.00 CLEAR 24'-1" _____.00 BRONZE 24'-1" _____.00</p>

CASCADE ALUMINUM, INC. HAS NO CONTROL OVER THE USE OF IT'S PRODUCTS.  
THE OWNER, THE ARCHITECT AND THE INSTALLER ARE RESPONSIBLE FOR THE SELECTION OF  
THE PROPER SYSTEMS AND SIZES TO COMPLY WITH ALL APPLICABLE BUILDING AND SAFETY LAWS.









# CASCADE ALUMINUM, INC.

ENTRANCES, EXTRUSIONS & ANODIZING

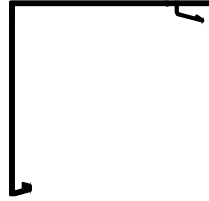
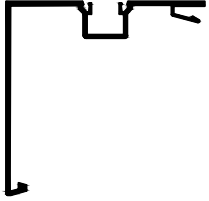
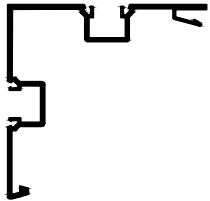
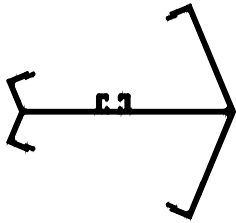
## SERIES # 150 1 3/4" x 4 1/2" CENTER GLAZE

1" INSULATED GLASS SYSTEM FOR INTERIOR AND EXTERIOR GLAZING

### QUARTER SIZE DETAILS

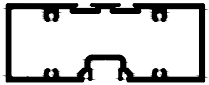
 <p>( <b>DETAIL # 13</b> )</p> <p>ENCAPSULATED SILL FLASHING</p> <p><b>PART# SF200</b></p>	 <p>( <b>DETAIL # 14</b> )</p> <p>POST WRAP OR SPECIAL CORNERS</p> <p><b>PART# PW450</b></p>	 <p>( <b>DETAIL # 15</b> )</p> <p>CORNER POST BEAUTY CAP</p> <p><b>PART# CP450</b></p>	 <p>( <b>DETAIL # 16</b> )</p> <p>SINGLE POCKET CORNER POST</p> <p><b>PART# CP151</b></p>
<p>CLEAR 21'-7" _____.00</p> <p>BRONZE 21'-7" _____.00</p>	<p>CLEAR 24'-1" _____.00</p> <p>BRONZE 24'-1" _____.00</p>	<p>CLEAR 24'-1" _____.00</p> <p>BRONZE 24'-1" _____.00</p>	<p>CLEAR 24'-1" _____.00</p> <p>BRONZE 24'-1" _____.00</p>
 <p>( <b>DETAIL # 17</b> )</p> <p>DOUBLE POCKET CORNER POST</p> <p><b>PART# CP152</b></p>	 <p>( <b>DETAIL # 18</b> )</p> <p>135° POST</p> <p><b>PART# 135° POST</b></p>	 <p>( <b>DETAIL # 19</b> )</p> <p>CENTER HUNG DOOR JAMB</p> <p><b>PART# J151</b></p>	 <p>( <b>DETAIL # 20</b> )</p> <p>CENTER HUNG DOOR HEADER</p> <p><b>PART# H150 / P400</b></p>
<p>CLEAR 24'-1" _____.00</p> <p>BRONZE 24'-1" _____.00</p>	<p>CLEAR 24'-1" _____.00</p> <p>BRONZE 24'-1" _____.00</p>	<p>CLEAR 24'-1" _____.00</p> <p>BRONZE 24'-1" _____.00</p>	<p>CLEAR 24'-3" _____.00</p> <p>BRONZE 24'-3" _____.00</p>
 <p>( <b>DETAIL # 21</b> )</p> <p>TRANSOM SASH INCLUDES CLIP</p> <p><b>PART# S15</b></p>	 <p>( <b>DETAIL # 22</b> )</p> <p>DOOR STOP</p> <p><b>PART# S45</b></p>	 <p>( <b>DETAIL # 23</b> )</p> <p>REGLET FILLER</p> <p><b>PART# P100</b></p>	 <p>( <b>DETAIL # 24</b> )</p> <p>TUBULAR DOOR HEADER</p> <p><b>PART# DH150</b></p>
<p>CLEAR 24'-1" _____.00</p> <p>BRONZE 24'-1" _____.00</p>	<p>CLEAR 21'-2" _____.00</p> <p>BRONZE 21'-2" _____.00</p>	<p>CLEAR 24'-1" _____.00</p> <p>BRONZE 24'-1" _____.00</p>	<p>CLEAR 24'-3" _____.00</p> <p>BRONZE 24'-3" _____.00</p>

CASCADE ALUMINUM, INC. HAS NO CONTROL OVER THE USE OF IT'S PRODUCTS.  
THE OWNER, THE ARCHITECT AND THE INSTALLER ARE RESPONSIBLE FOR THE SELECTION OF  
THE PROPER SYSTEMS AND SIZES TO COMPLY WITH ALL APPLICABLE BUILDING AND SAFETY LAWS.





# CASCADE ALUMINUM, INC.

ENTRANCES, EXTRUSIONS & ANODIZING

## SERIES # 150 1 3/4" x 4 1/2" CENTER GLAZE

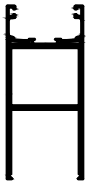
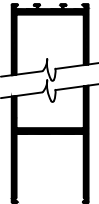
1" INSULATED GLASS SYSTEM FOR INTERIOR AND EXTERIOR GLAZING

### QUARTER SIZE DETAILS

 <p>( <b>DETAIL # 25</b> ) 3 11/16" BULKHEAD WITH STOP <b>PART# BR802</b></p>	 <p>( <b>DETAIL # 26</b> ) 6" BULKHEAD WITH STOP <b>PART# WSTR</b></p>	 <p>( <b>DETAIL # 27</b> ) 10" BULKHEAD WITH STOP <b>PART# 9 1/2"BR</b></p>	 <p>( <b>DETAIL # 28</b> ) S.G. GLASS STOP FOR ALL BULKHEADS <b>PART# SG-STOP</b></p>
<p>CLEAR 21'-6" _____.00</p>	<p>CLEAR 19'-8" _____.00</p>	<p>CLEAR 21'-6" _____.00</p>	<p>CLEAR 18'-2" _____.00</p>
<p>BRONZE 21'-6" _____.00</p>	<p>BRONZE 19'-8" _____.00</p>	<p>BRONZE 21'-6" _____.00</p>	<p>BRONZE 18'-2" _____.00</p>
 <p>( <b>DETAIL # 29</b> ) HORIZONTAL CLIP JOINT <b>PART# HC100</b></p>			
<p>CLEAR 1 1/4" _____.00</p>			
<p>BRONZE 1 1/4" _____.00</p>			







CASCADE ALUMINUM, INC. HAS NO CONTROL OVER THE USE OF IT'S PRODUCTS.  
THE OWNER, THE ARCHITECT AND THE INSTALLER ARE RESPONSIBLE FOR THE SELECTION OF  
THE PROPER SYSTEMS AND SIZES TO COMPLY WITH ALL APPLICABLE BUILDING AND SAFETY LAWS.

# CASCADE ALUMINUM, INC.

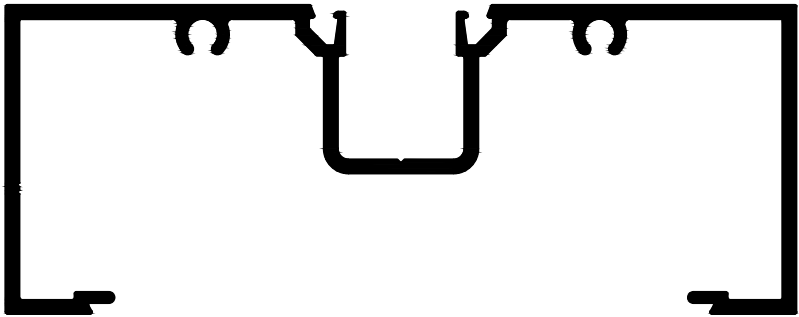
ENTRANCES, EXTRUSIONS & ANODIZING

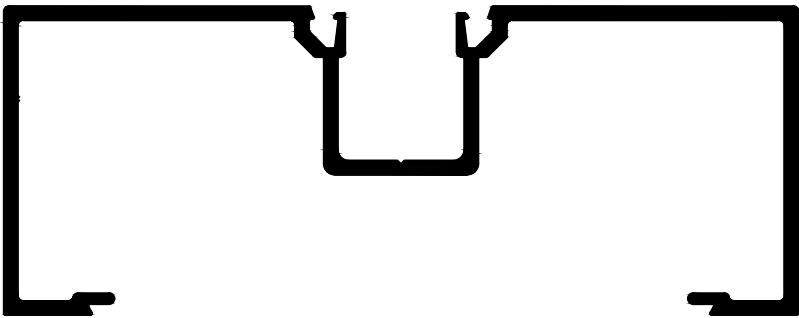
## SERIES # 150 1 3/4" x 4 1/2" CENTER GLAZE

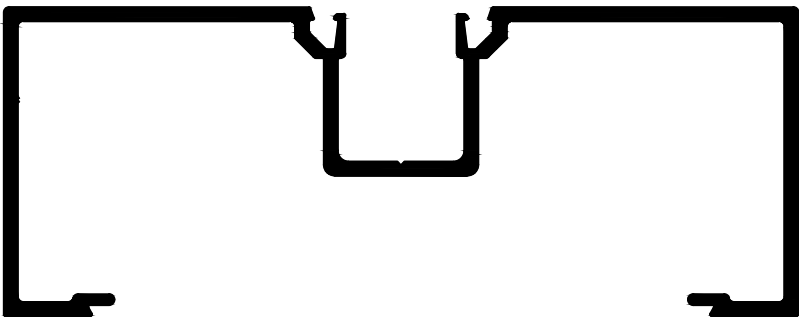
1" INSULATED GLASS SYSTEM FOR INTERIOR AND EXTERIOR GLAZING

FULL SIZE DETAILS	DETAIL NUMBER	QUARTER SIZE DETAILS
	1	 (DETAIL # 1) VERTICAL OR HEAD <b>PART# V152</b> <hr/> AVAILABLE IN 24'-1" LENGTH
	2	 (DETAIL # 2) VERTICAL NO SPLINE <b>PART# V157</b> <hr/> AVAILABLE IN 24'-1" LENGTH
	3	 (DETAIL # 3) VERTICAL NO SPLINE <b>PART# V157</b> <hr/> AVAILABLE IN 21'-7" LENGTHS







CASCADE ALUMINUM, INC. HAS NO CONTROL OVER THE USE OF IT'S PRODUCTS.  
 THE OWNER, THE ARCHITECT AND THE INSTALLER ARE RESPONSIBLE FOR THE SELECTION OF  
 THE PROPER SYSTEMS AND SIZES TO COMPLY WITH ALL APPLICABLE BUILDING AND SAFETY LAWS.

# CASCADE ALUMINUM, INC.

ENTRANCES, EXTRUSIONS & ANODIZING

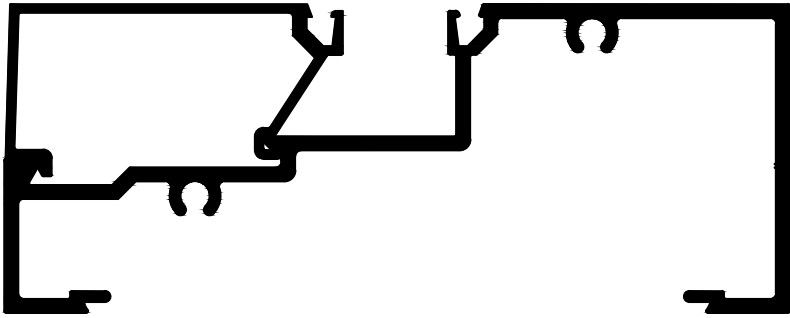
## SERIES # 150 1 3/4" x 4 1/2" CENTER GLAZE

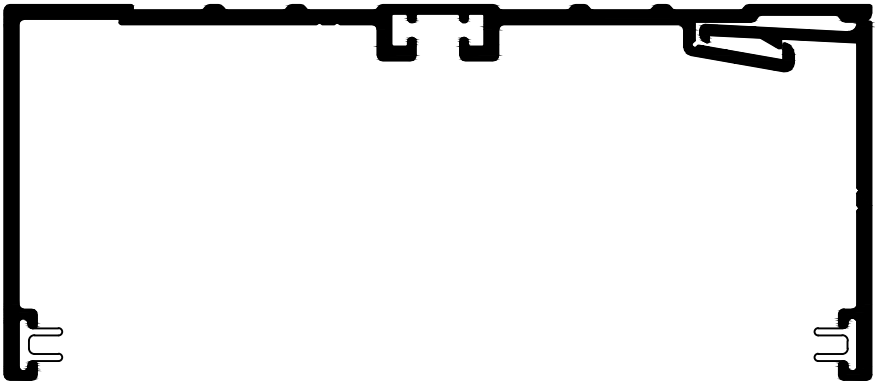
1" INSULATED GLASS SYSTEM FOR INTERIOR AND EXTERIOR GLAZING

FULL SIZE DETAILS	DETAIL NUMBER	QUARTER SIZE DETAILS
	4	 <p>(DETAIL # 4)</p> <p>POCKET FILLER</p> <p><b>PART# F100</b></p> <p>AVAILABLE IN 24'-1" LENGTH</p>
	5	 <p>(DETAIL # 5)</p> <p>SILL OR INTERMEDIATE HORIZONTAL WHEN USED WITH F100</p> <p><b>PART# H153/ST</b></p> <p>AVAILABLE IN 24'-1" LENGTH</p>
	6	 <p>(DETAIL # 6)</p> <p>TWO PIECE COMPENSATION CHANNEL INCLUDES GASKET</p> <p><b>PART# CC450/ST</b></p> <p>AVAILABLE IN 24'-1" LENGTH</p>







CASCADE ALUMINUM, INC. HAS NO CONTROL OVER THE USE OF IT'S PRODUCTS.  
THE OWNER, THE ARCHITECT AND THE INSTALLER ARE RESPONSIBLE FOR THE SELECTION OF  
THE PROPER SYSTEMS AND SIZES TO COMPLY WITH ALL APPLICABLE BUILDING AND SAFETY LAWS.

# CASCADE ALUMINUM, INC.

ENTRANCES, EXTRUSIONS & ANODIZING

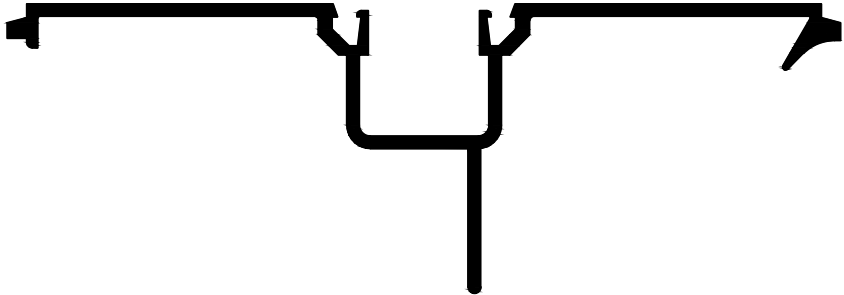
## SERIES # 150 1 3/4" x 4 1/2" CENTER GLAZE

1" INSULATED GLASS SYSTEM FOR INTERIOR AND EXTERIOR GLAZING

FULL SIZE DETAILS	DETAIL NUMBER	QUARTER SIZE DETAILS
	7	 <p>(DETAIL # 7) 2" x 4 1/2" COMPENSATION CHANNEL OR HEAD CAN <b>PART# IHC450</b></p> <p>AVAILABLE IN 24'-1" LENGTH</p>
	8	 <p>(DETAIL # 8) HEAD CAN INSERT <b>PART# HI221</b></p> <p>AVAILABLE IN 24'-1" LENGTH</p>
	9	 <p>(DETAIL # 9) SILL CAN <b>PART# S222</b></p> <p>AVAILABLE IN 24'-1" LENGTH</p>







CASCADE ALUMINUM, INC. HAS NO CONTROL OVER THE USE OF IT'S PRODUCTS.  
THE OWNER, THE ARCHITECT AND THE INSTALLER ARE RESPONSIBLE FOR THE SELECTION OF  
THE PROPER SYSTEMS AND SIZES TO COMPLY WITH ALL APPLICABLE BUILDING AND SAFETY LAWS.

# CASCADE ALUMINUM, INC.

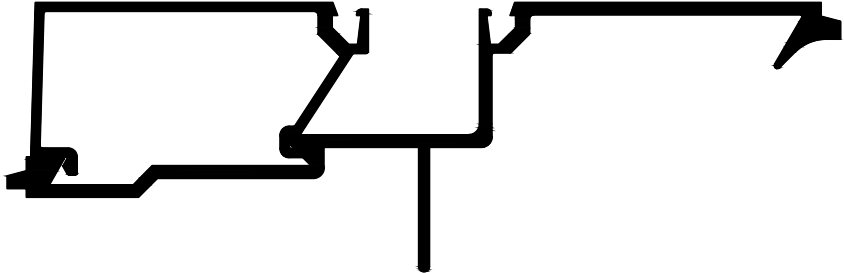
ENTRANCES, EXTRUSIONS & ANODIZING

## SERIES # 150 1 3/4" x 4 1/2" CENTER GLAZE

1" INSULATED GLASS SYSTEM FOR INTERIOR AND EXTERIOR GLAZING

FULL SIZE DETAILS	DETAIL NUMBER	QUARTER SIZE DETAILS
	<b>10</b>	 (DETAIL # 10) SILL CAN INSERT WITH STOP <b>PART# SI223/ST</b> AVAILABLE IN 24'-1" LENGTH
	<b>11</b>	 (DETAIL # 11) GLASS STOP FOR H153, S1223 <b>PART# HS153</b> AVAILABLE IN 24'-1" LENGTH
	<b>12</b>	 (DETAIL # 12) FLAT FILLER <b>PART# FF200</b> AVAILABLE IN 24'-1" LENGTH





CASCADE ALUMINUM, INC. HAS NO CONTROL OVER THE USE OF IT'S PRODUCTS.  
 THE OWNER, THE ARCHITECT AND THE INSTALLER ARE RESPONSIBLE FOR THE SELECTION OF  
 THE PROPER SYSTEMS AND SIZES TO COMPLY WITH ALL APPLICABLE BUILDING AND SAFETY LAWS.

# CASCADE ALUMINUM, INC.

ENTRANCES, EXTRUSIONS & ANODIZING

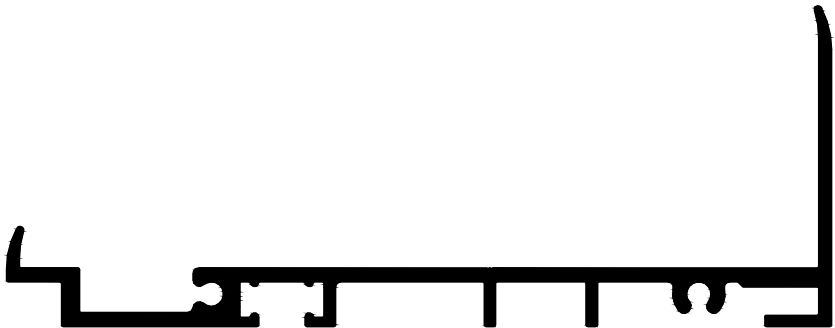
## SERIES # 150 1 3/4" x 4 1/2" CENTER GLAZE

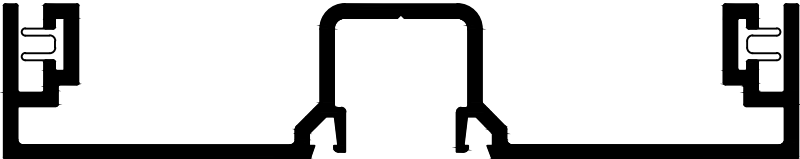
1" INSULATED GLASS SYSTEM FOR INTERIOR AND EXTERIOR GLAZING

FULL SIZE DETAILS	DETAIL NUMBER	QUARTER SIZE DETAILS
	<p><b>13</b></p>	 <p>(DETAIL # 13)</p> <p>ENCAPSULATED SILL FLASHING</p> <p><b>PART# SF200</b></p> <p>AVAILABLE IN 24'-1" LENGTH</p>
	<p><b>14</b></p>	 <p>(DETAIL # 14)</p> <p>POST WRAP OR SPECIAL CORNERS</p> <p><b>PART# PW450</b></p> <p>AVAILABLE IN 24'-1" LENGTH</p>

CASCADE ALUMINUM, INC. HAS NO CONTROL OVER THE USE OF IT'S PRODUCTS.  
THE OWNER, THE ARCHITECT AND THE INSTALLER ARE RESPONSIBLE FOR THE SELECTION OF  
THE PROPER SYSTEMS AND SIZES TO COMPLY WITH ALL APPLICABLE BUILDING AND SAFETY LAWS.



# CASCADE ALUMINUM, INC.

ENTRANCES, EXTRUSIONS & ANODIZING

## SERIES # 150 1 3/4" x 4 1/2" CENTER GLAZE

1" INSULATED GLASS SYSTEM FOR INTERIOR AND EXTERIOR GLAZING

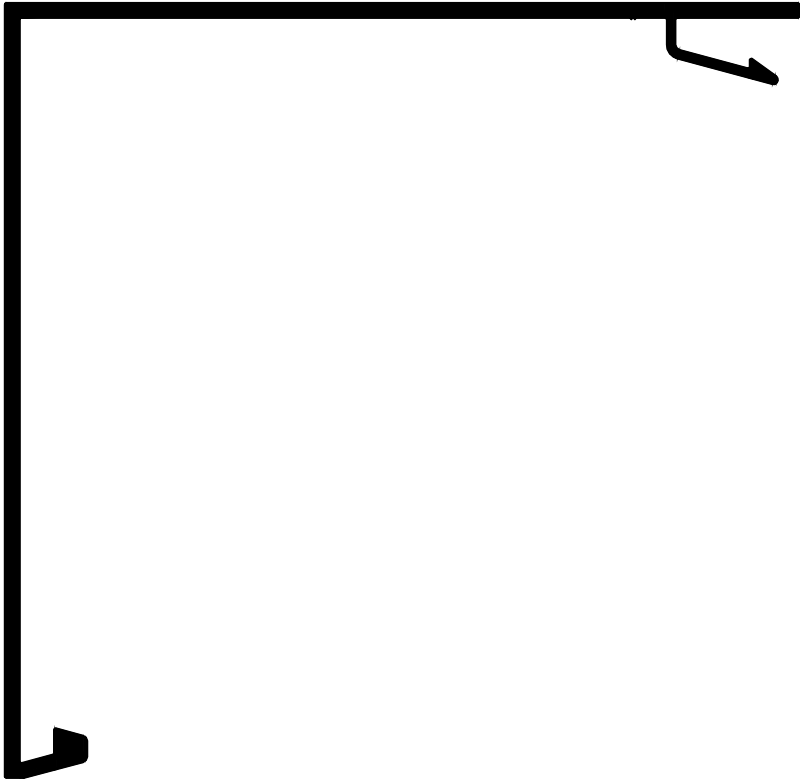
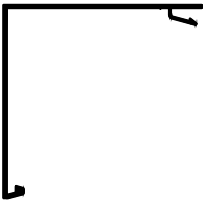
FULL SIZE DETAILS	DETAIL NUMBER	QUARTER SIZE DETAILS
	<b>15</b>	 <p>(DETAIL # 15)</p> <p>CORNER POST BEAUTY CAP</p> <p><b>PART# CP450</b></p> <p>AVAILABLE IN 24'-1" LENGTH</p>

CASCADE ALUMINUM, INC. HAS NO CONTROL OVER THE USE OF IT'S PRODUCTS.  
THE OWNER, THE ARCHITECT AND THE INSTALLER ARE RESPONSIBLE FOR THE SELECTION OF  
THE PROPER SYSTEMS AND SIZES TO COMPLY WITH ALL APPLICABLE BUILDING AND SAFETY LAWS.

# CASCADE ALUMINUM, INC.

ENTRANCES, EXTRUSIONS & ANODIZING

## SERIES # 150 1 3/4" x 4 1/2" CENTER GLAZE

1" INSULATED GLASS SYSTEM FOR INTERIOR AND EXTERIOR GLAZING

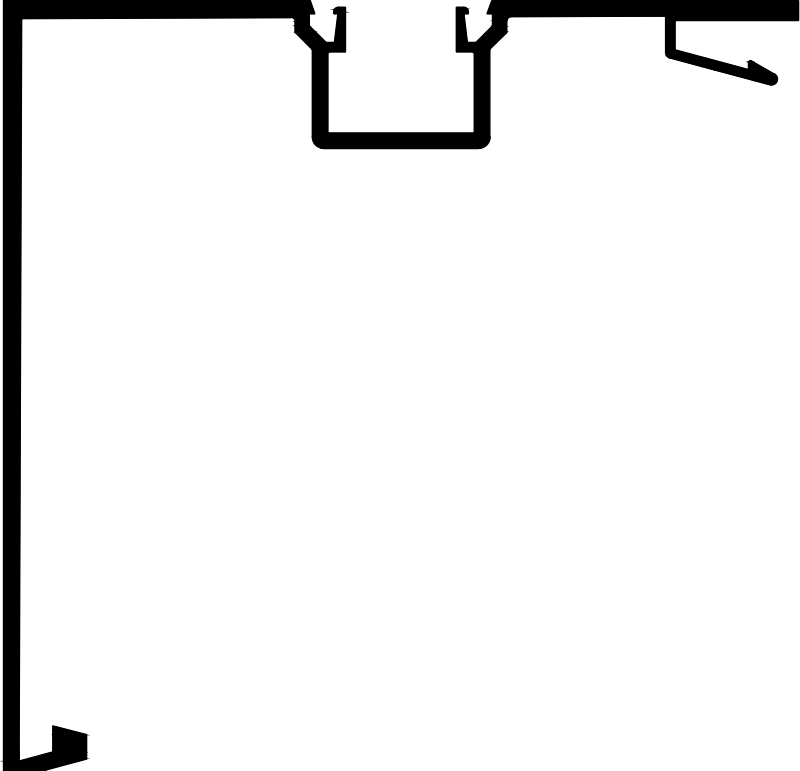
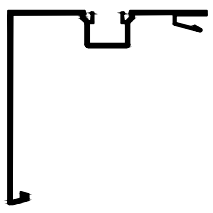
FULL SIZE DETAILS	DETAIL NUMBER	QUARTER SIZE DETAILS
	<b>16</b>	 <p>(DETAIL # 16)</p> <p>SINGLE POCKET CORNER POST</p> <p><b>PART# CP151</b></p> <p>AVAILABLE IN 24'-1" LENGTH</p>

CASCADE ALUMINUM, INC. HAS NO CONTROL OVER THE USE OF IT'S PRODUCTS.  
THE OWNER, THE ARCHITECT AND THE INSTALLER ARE RESPONSIBLE FOR THE SELECTION OF  
THE PROPER SYSTEMS AND SIZES TO COMPLY WITH ALL APPLICABLE BUILDING AND SAFETY LAWS.

# CASCADE ALUMINUM, INC.

ENTRANCES, EXTRUSIONS & ANODIZING

## SERIES # 150 1 3/4" x 4 1/2" CENTER GLAZE

1" INSULATED GLASS SYSTEM FOR INTERIOR AND EXTERIOR GLAZING

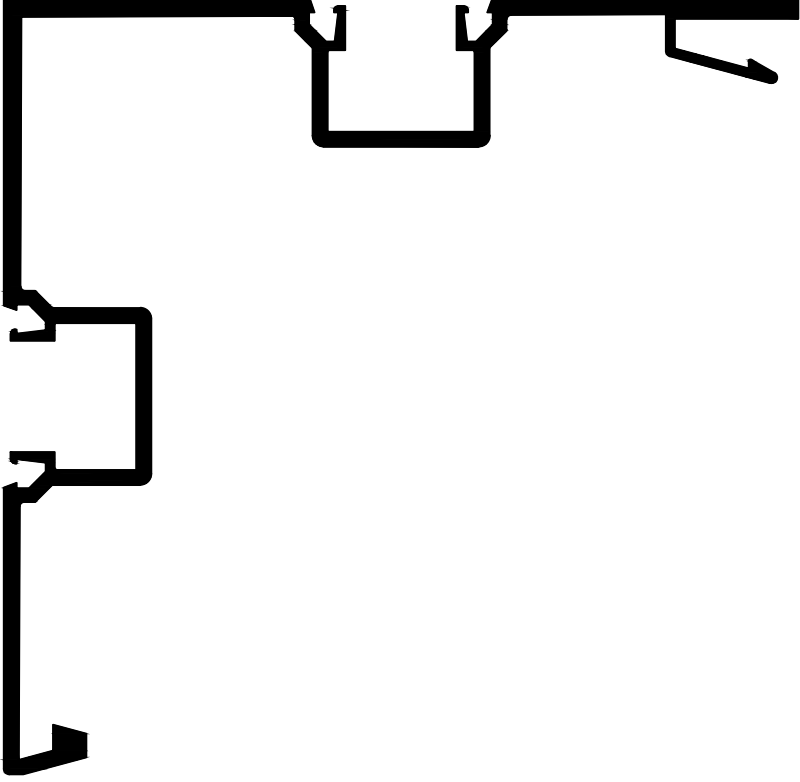
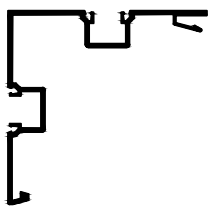
FULL SIZE DETAILS	DETAIL NUMBER	QUARTER SIZE DETAILS
	<b>17</b>	 <p data-bbox="1230 777 1461 808">(DETAIL # 17)</p> <p data-bbox="1247 840 1445 892">DOUBLE POCKET CORNER POST</p> <p data-bbox="1242 1722 1453 1753"><b>PART# CP152</b></p> <p data-bbox="1258 1785 1437 1837">AVAILABLE IN 24'-1" LENGTH</p>

CASCADE ALUMINUM, INC. HAS NO CONTROL OVER THE USE OF IT'S PRODUCTS.  
THE OWNER, THE ARCHITECT AND THE INSTALLER ARE RESPONSIBLE FOR THE SELECTION OF  
THE PROPER SYSTEMS AND SIZES TO COMPLY WITH ALL APPLICABLE BUILDING AND SAFETY LAWS.

# CASCADE ALUMINUM, INC.

ENTRANCES, EXTRUSIONS & ANODIZING

## SERIES # 150 1 3/4" x 4 1/2" CENTER GLAZE

1" INSULATED GLASS SYSTEM FOR INTERIOR AND EXTERIOR GLAZING

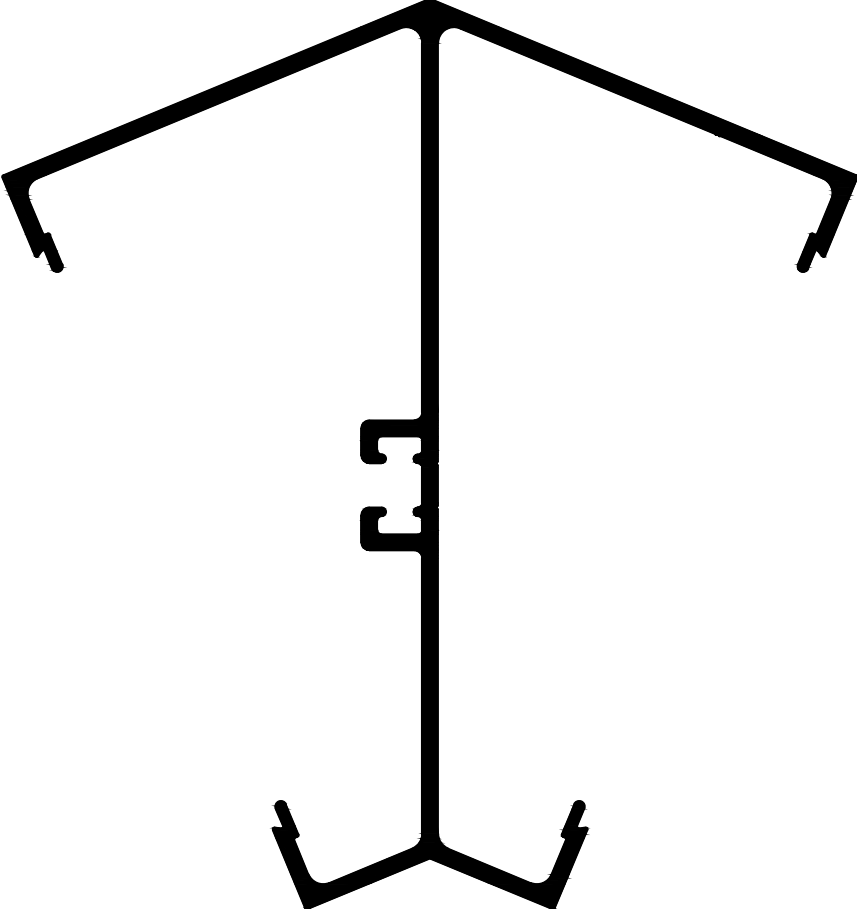
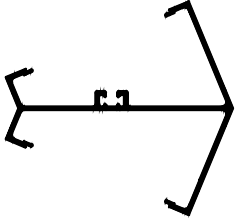
FULL SIZE DETAILS	DETAIL NUMBER	QUARTER SIZE DETAILS
	<b>18</b>	 <p>(DETAIL # 18 135° POST</p> <p><b>PART# 135° POST</b></p> <p>AVAILABLE IN 24'-1" LENGTH</p>





CASCADE ALUMINUM, INC. HAS NO CONTROL OVER THE USE OF IT'S PRODUCTS.  
THE OWNER, THE ARCHITECT AND THE INSTALLER ARE RESPONSIBLE FOR THE SELECTION OF  
THE PROPER SYSTEMS AND SIZES TO COMPLY WITH ALL APPLICABLE BUILDING AND SAFETY LAWS.

# CASCADE ALUMINUM, INC.

ENTRANCES, EXTRUSIONS & ANODIZING

## SERIES # 150 1 3/4" x 4 1/2" CENTER GLAZE

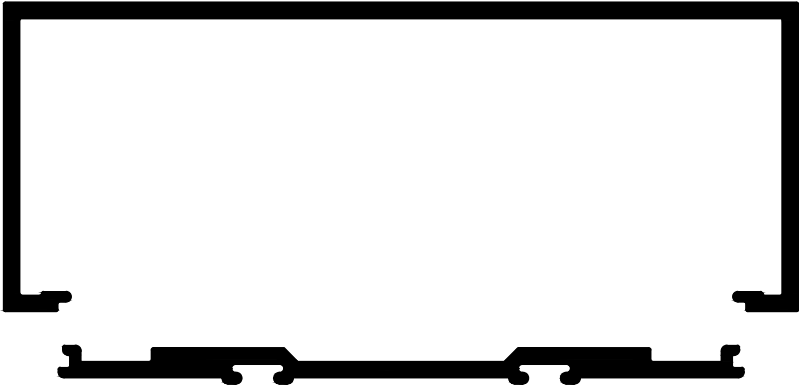
1" INSULATED GLASS SYSTEM FOR INTERIOR AND EXTERIOR GLAZING

FULL SIZE DETAILS	DETAIL NUMBER	QUARTER SIZE DETAILS
	<b>19</b>	 ( <b>DETAIL # 19</b> )  CENTER HUNG DOOR JAMB  <b>PART# J151</b>
		<b>AVAILABLE IN 24'-1" LENGTH</b>
	<b>20</b>	 ( <b>DETAIL # 20</b> )  CENTER HUNG DOOR HEADER  <b>PART# H150 / P400</b>
		<b>AVAILABLE IN 24'-3" LENGTH</b>







CASCADE ALUMINUM, INC. HAS NO CONTROL OVER THE USE OF IT'S PRODUCTS.  
THE OWNER, THE ARCHITECT AND THE INSTALLER ARE RESPONSIBLE FOR THE SELECTION OF  
THE PROPER SYSTEMS AND SIZES TO COMPLY WITH ALL APPLICABLE BUILDING AND SAFETY LAWS.

# CASCADE ALUMINUM, INC.

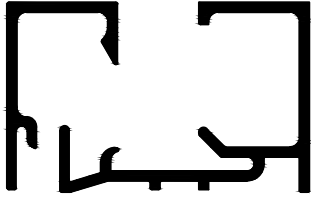
ENTRANCES, EXTRUSIONS & ANODIZING

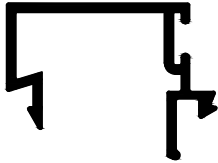
## SERIES # 150 1 3/4" x 4 1/2" CENTER GLAZE

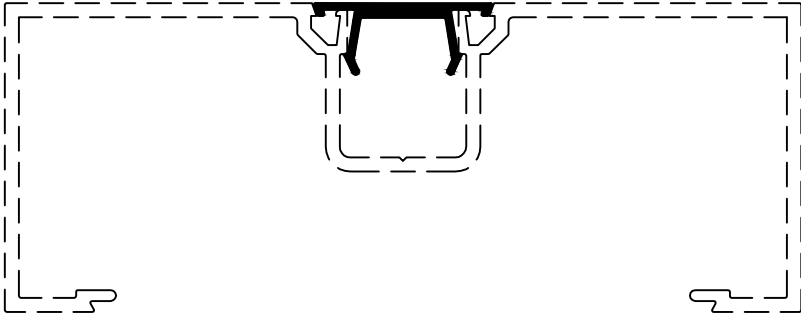
1" INSULATED GLASS SYSTEM FOR INTERIOR AND EXTERIOR GLAZING

FULL SIZE DETAILS	DETAIL NUMBER	QUARTER SIZE DETAILS
	<b>21</b>	 ( <b>DETAIL # 21</b> )  TRANSOM SASH INCLUDES CLIP  <b>PART# S15</b>  AVAILABLE IN 24'-1" LENGTH
	<b>22</b>	 ( <b>DETAIL # 22</b> )  DOOR STOP  <b>PART# S45</b>  AVAILABLE IN 21'-2" LENGTH
	<b>23</b>	 ( <b>DETAIL # 23</b> )  REGLET FILLER  <b>PART# P100</b>  AVAILABLE IN 24'-1" LENGTH



CASCADE ALUMINUM, INC. HAS NO CONTROL OVER THE USE OF IT'S PRODUCTS.  
 THE OWNER, THE ARCHITECT AND THE INSTALLER ARE RESPONSIBLE FOR THE SELECTION OF  
 THE PROPER SYSTEMS AND SIZES TO COMPLY WITH ALL APPLICABLE BUILDING AND SAFETY LAWS.

# CASCADE ALUMINUM, INC.

ENTRANCES, EXTRUSIONS & ANODIZING

## SERIES # 150 1 3/4" x 4 1/2" CENTER GLAZE

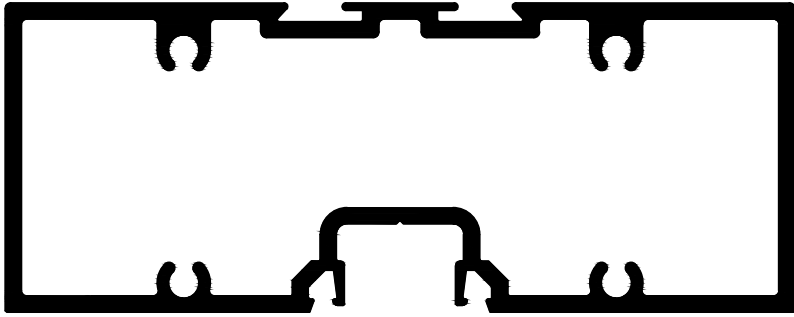
1" INSULATED GLASS SYSTEM FOR INTERIOR AND EXTERIOR GLAZING

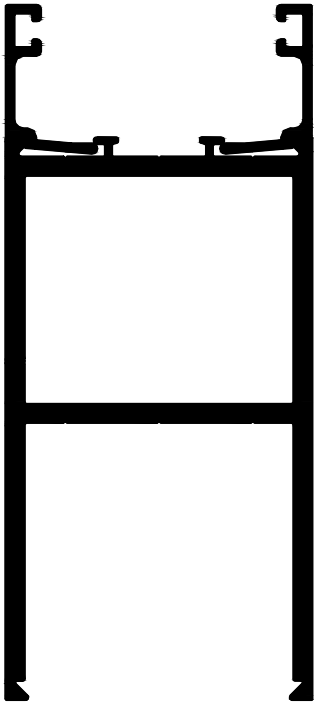
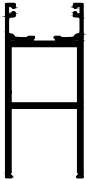
FULL SIZE DETAILS	DETAIL NUMBER	QUARTER SIZE DETAILS
	<p><b>24</b></p>	 <p>(DETAIL # 24)</p> <p>TUBULAR DOOR HEADER</p> <p><b>PART# DH150</b></p> <hr/> <p>AVAILABLE IN 24'-3" LENGTH</p>
	<p><b>25</b></p>	 <p>(DETAIL # 25)</p> <p>3 3/4" BULKHEAD WITH STOP</p> <p><b>PART# BR802</b></p> <hr/> <p>AVAILABLE IN 21'-6" LENGTH</p>

CASCADE ALUMINUM, INC. HAS NO CONTROL OVER THE USE OF IT'S PRODUCTS.  
 THE OWNER, THE ARCHITECT AND THE INSTALLER ARE RESPONSIBLE FOR THE SELECTION OF  
 THE PROPER SYSTEMS AND SIZES TO COMPLY WITH ALL APPLICABLE BUILDING AND SAFETY LAWS.

# CASCADE ALUMINUM, INC.

ENTRANCES, EXTRUSIONS & ANODIZING

## SERIES # 150 1 3/4" x 4 1/2" CENTER GLAZE

1" INSULATED GLASS SYSTEM FOR INTERIOR AND EXTERIOR GLAZING

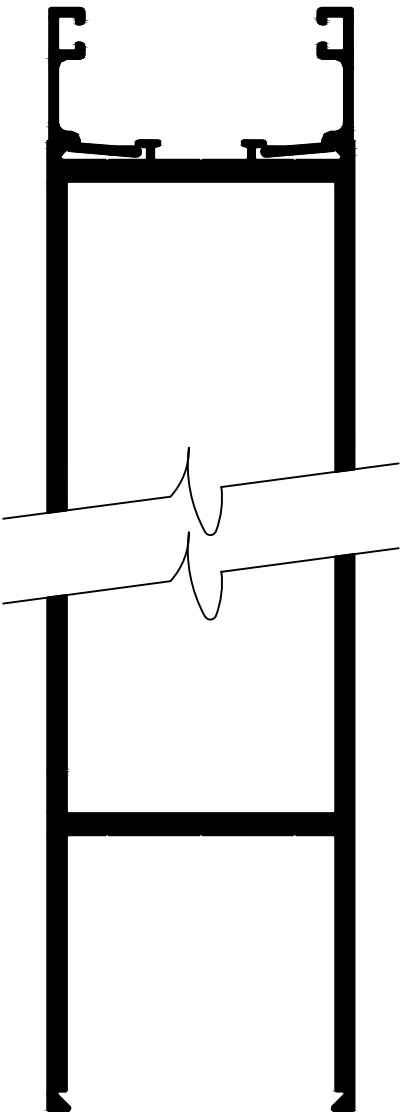
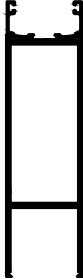
FULL SIZE DETAILS	DETAIL NUMBER	QUARTER SIZE DETAILS
	<h3>26</h3>	 <p>(DETAIL # 26 )</p> <p>6 1/4" BULKHEAD WITH STOP</p> <p><b>PART# WSTR</b></p> <p>AVAILABLE IN 19'-8" LENGTH</p>
		<h3>27</h3>

CASCADE ALUMINUM, INC. HAS NO CONTROL OVER THE USE OF IT'S PRODUCTS.  
 THE OWNER, THE ARCHITECT AND THE INSTALLER ARE RESPONSIBLE FOR THE SELECTION OF  
 THE PROPER SYSTEMS AND SIZES TO COMPLY WITH ALL APPLICABLE BUILDING AND SAFETY LAWS.







# CASCADE ALUMINUM, INC.

ENTRANCES, EXTRUSIONS & ANODIZING

## SERIES # 150 1 3/4" x 4 1/2" CENTER GLAZE

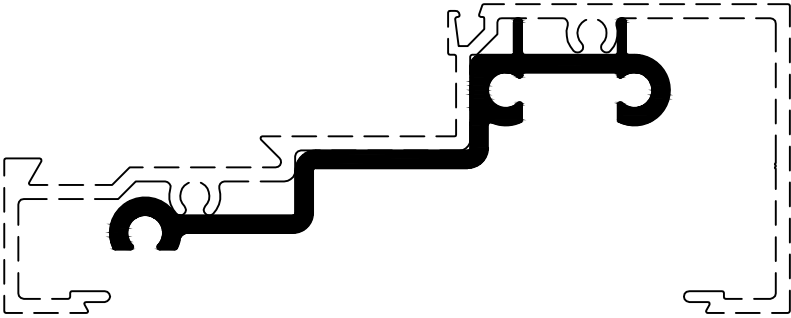
1" INSULATED GLASS SYSTEM FOR INTERIOR AND EXTERIOR GLAZING

FULL SIZE DETAILS	DETAIL NUMBER	QUARTER SIZE DETAILS
	<p><b>28</b></p>	<div style="text-align: center;">  <p>( <b>DETAIL # 28</b> )</p> <p>SG GLASS STOP FOR ALL BULKHEADS</p> <p><b>PART# SG-STOP</b></p> <p>AVAILABLE IN 18'-2" LENGTH</p> </div>
	<p><b>29</b></p>	<div style="text-align: center;">  <p>( <b>DETAIL # 29</b> )</p> <p>HORIZONTAL CLIP JOINT</p> <p><b>PART# HC100</b></p> <p>AVAILABLE IN 1 1/4" LENGTH</p> </div>

CASCADE ALUMINUM, INC. HAS NO CONTROL OVER THE USE OF IT'S PRODUCTS.  
 THE OWNER, THE ARCHITECT AND THE INSTALLER ARE RESPONSIBLE FOR THE SELECTION OF  
 THE PROPER SYSTEMS AND SIZES TO COMPLY WITH ALL APPLICABLE BUILDING AND SAFETY LAWS.